



hallicrafters

OPERATING AND SERVICE INSTRUCTIONS

**COMMUNICATIONS
TRANSCEIVER
MODEL SR-150**



Figure 1. Hallicrafters Model SR-150 Transceiver.

SECTION I

GENERAL DESCRIPTION

The Hallicrafters Model SR-150 Transceiver is a precision-built, compact, high-performance radio equipment of advanced design. This transceiver utilizes 19 tubes and a dual conversion IF to provide for the transmission and reception of single-sideband (SSB) and continuous wave (CW) signals on the 80, 40, 20, 15, and 10 meter bands.

The versatility of SR-150 equipment permits it to be operated as a fixed station or as a mobile equipment. A 117-volt, 50/60-cycle, AC power supply, complete with speaker (Model PS-150-120), is available for fixed-station use; a 12-volt DC power supply, Model PS-150-12, and a mobile mounting rack (Model MR-150) are available when the transceiver is to be used in a mobile configuration.

An advanced feature of the SR-150 equipment is the Receiver Incremental Tuning (RIT) control. This control enables the operator to unlock the receiver frequency and tune the receiver approximately two KC either side of the transmitter frequency. Flipping the RIT switch OFF automatically returns the equipment to the transceiver condition.

Another special feature is the amplified Automatic Audio Level Control (AALC) which functions in the transmit mode. The AALC circuitry prevents splatter due to severe flat-topping of the final amplifier by providing about 15 DB of compression after a small amount of flat-topping occurs.

Other features of the Model SR-150 Transceiver include:

- A stable, accurately-calibrated VFO.
- A built-in, 100-KC crystal calibrator.
- Upper and lower sideband, MOX, (push-to-talk), VOX, Manual CW, and break-in CW operation.
- A crystal-lattice filter.
- A product detector.
- An S-meter/RF output level indicator.

IMPORTANT

Do not, under any circumstance, attempt to operate the SR-150 equipment before becoming completely familiar with the instructions contained within this manual.

SECTION II

TECHNICAL DATA

FREQUENCY COVERAGE:

Eight-band capability — Full coverage provided for 80, 40, 20, 15, and one segment of the 10-meter band. Provisions made and crystals available for the remaining three segments of the 10-meter band. Other frequencies are available on request.

OPERATION:

Single Sideband — VOX or MOX (push-to-talk).
CW — Manual or break-in.

FRONT PANEL CONTROLS:

Tuning; Band Selector; Final Tuning; RF Level - Mic Gain; Preselector; RIT; RF Gain - AF Gain; Operation (Off/Standby/MOX/VOX); Function (CW/USB/LSB); Cal; Cal Adj.

GENERAL:

Dial Calibration — 5-KC increments (Built-in, 100-KC crystal calibrator).

Calibration Accuracy — Less than 2 KC between 100-KC points after indexing.

VFO — 500 KC tunable range.

Stability — Less than 300 CPS after warmup.

Tubes — 18 plus one voltage regulator, ten diodes, and one varicap.

Ambient Temperature Range — Minus 20° to plus 50° C.

Construction — Rugged, lightweight aluminum.

Dimensions (HWD) — 6-1/2 inches by 15 inches by 13 inches.

Net Weight — 17-1/2 pounds.

Shipping Weight — 22 pounds (approximately).

TRANSMITTER:

Output Tubes — Two 12DQ6B tubes in parallel.

Output Impedance — Fixed, 50-ohm pi-network.

Power Input — SSB 150 watts PEP MAX.
CW 125 watts MAX.

Carrier and Unwanted Sideband Suppression — 50 DB.

Distortion Products — 30 DB.

Audio Response — 600 CPS to 2800 CPS@3 DB.

Microphone Input — High impedance.

RECEIVER:

Sensitivity — 1 microvolt for a 20-DB signal-to-noise ratio.

Audio Output — 2 watts.

Output Impedance — 3.2 ohms and 500 ohms.

Overall Gain — 1 microvolt for 1/2 watt output.

Antenna Input — 50 ohms.

IF — Dual Conversion:

First IF 6.0 MC to 6.5 MC variable (tunes with the VFO).

Second IF 1650 KC, crystal-lattice filter.

ACCESSORIES:

Mobile Mounting Rack Model MR-150 — Quick release design adaptable to transmission hump or floor mount... all connections made simultaneously... access holes for VOX controls.

Net Weight — 10 pounds.

Shipping Weight — 12-3/4 pounds (approximately).

12-volt DC Power Supply Model PS-150-12 — Designed for out-of-the-way trunk installation... terminal strip provides for quick-and-easy connection to the cable from the mounting rack... contains five silicon diode rectifiers and four transistors.

Dimensions (HWD) — 3-3/4 inches by 10 inches by 6-3/4 inches.

Net Weight — 5-1/2 pounds.

Shipping Weight — 9 pounds (approximately).

117-volt AC Power Supply Model PS-150-120 — Styled as a companion unit to the Model SR-150 Transceiver, this supply also contains a 4-inch by 6-inch speaker... one-cable connection carries power to an audio from the transceiver... may be plugged into any 115-volt wall outlet... contains five silicon diode rectifiers.

Dimensions (HWD) — 6-1/4 inches by 7-1/2 inches by 10 inches.

Net Weight — 22 pounds.

Shipping Weight — 28-1/2 pounds (approximately).

TUBES AND FUNCTIONS

V1	6AZ8	Receiver RF Amplifier and Calibrate Oscillator.	V11	6T8A	Receiver First Audio, AGC Detector, VOX Diode, and QT Diode.
V2	12BA7	Receiver and Transmitter First Mixer.	V12	OA2	Voltage Regulator.
V3	6EA8	6.0-MC to 6.5-MC IF Amplifier and Audio Cathode Follower.	V13	6AQ5A	Receiver Audio Output.
V4	12BA7	Receiver Second Mixer.	V14	12DQ6B/ 12GW6	Power Amplifier.
V5	6EA8	Receiver Second 1650-KC IF Amplifier and AALC Amplifier.	V15	12DQ6B/ 12GW6	Power Amplifier.
V6	12BE6	Product Detector.	V16	12BY7A	Transmitter Driver.
V7	6AH6	Transmitter Second Mixer.	V17	6EA8	Receiver and Transmitter 1650-KC IF Amplifier and Meter Amplifier.
V8	12AT7	Heterodyne Oscillator and Cathode Follower.	V18	12AX7	First and Second Microphone Amplifier.
V9	6EA8	VFO and Cathode Follower.	V19	12AT7	VOX Amplifier and VOX Relay Amplifier.
V10	12AT7	Carrier Oscillator/BFO.			

SECTION III INSTALLATION

3-1. UNPACKING.

Carefully remove this equipment from its carton and packing material and examine it for any possible damage which may have occurred during transit. Should any sign of damage be apparent, immediately file a claim with the carrier stating the extent of the damage. Check all shipping labels and tags for special instructions before removing or destroying them.

3-2. LOCATION.

The Model SR-150 Transceiver may be placed in any location permitting free air circulation through the ventilation openings in the cabinet. However, excessively warm locations such as those adjacent to radiators and heating units should be avoided.

3-3. ANTENNAS.

Antenna connections are provided on the rear of the transceiver, as shown in figure 2. If a common antenna is used, the antenna switch (S2) should be in the down (common) position and the antenna connected to the bottom connector. If separate antennas are used, the switch should be up, the receiver antenna should be connected to the top

connector (J1), and the transmitter antenna connected to the bottom connector (J2).

Figure 3 shows an installation, in block diagram form, making use of a linear amplifier and an external antenna changeover relay. Connections to the power supply from the antenna changeover relay are internal solder connections. Refer to figures 14, 15, 17, and 18 for the internal chassis views and schematic diagrams of the power supplies used in conjunction with the Model SR-150 Transceiver. In the installation shown, the receiver is connected directly to the relay through the top antenna connector (J1); the transmitter is connected through the bottom antenna connector (J2) to the linear amplifier which, in turn, is connected to the relay. If desired, two separate antennas may be used in the installation shown, eliminating the use of the antenna changeover relay.

NOTE

Never operate the transceiver without making a connection to a proper antenna or to a resistive dummy load.

Refer to the ARRL handbook or similar publications for the selection and installation of antennas.

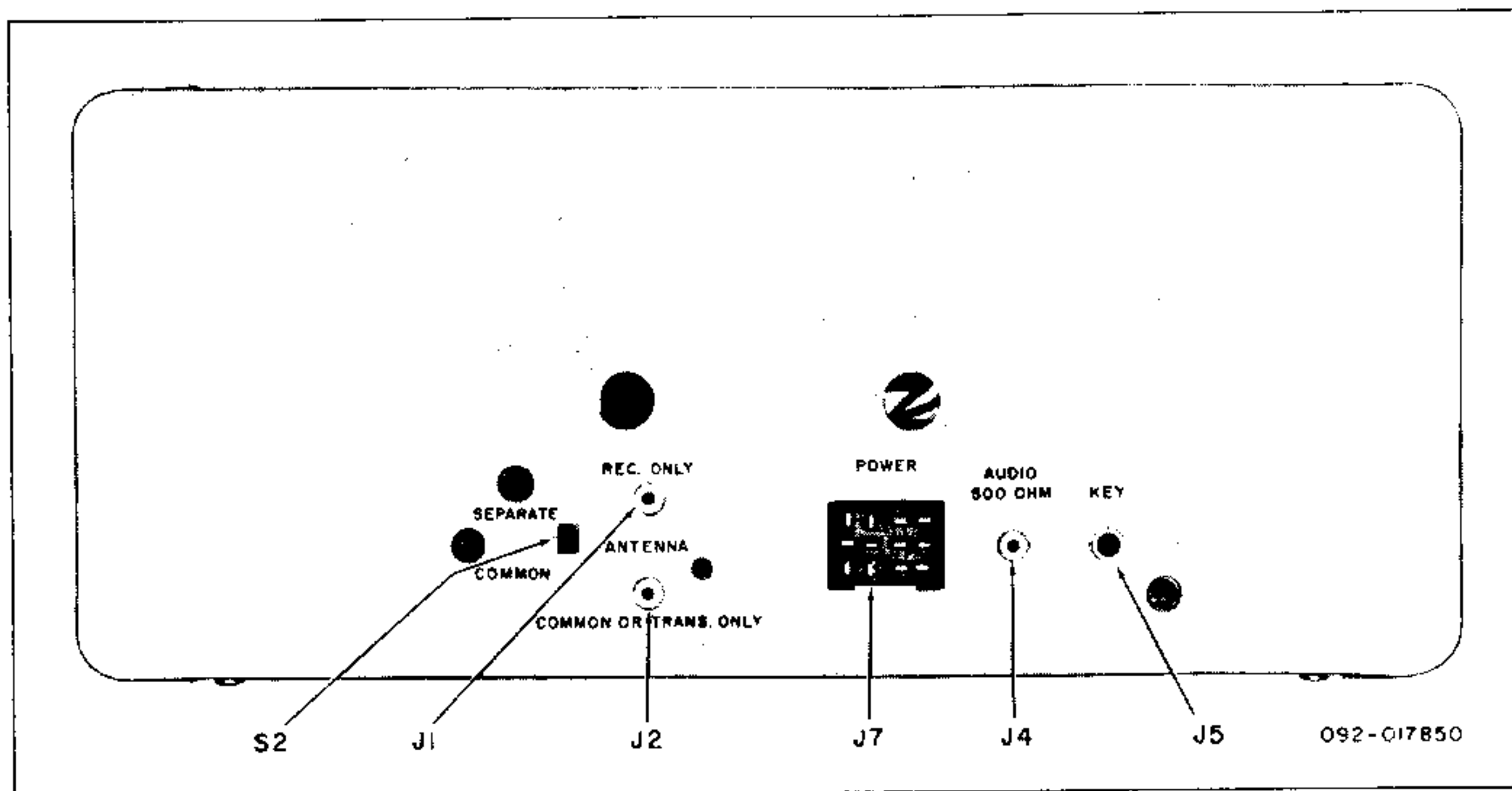

Figure 2. Rear View of Transceiver.

3.4. MOBILE INSTALLATION.

The Model SR-150 Transceiver may be installed in any vehicle having a 12-volt DC power source. To complete this mobile installation, a Model PS-150-12 Power Supply and a Model MR-150 Mobile Mounting Rack will be required. The PS-150-12 Power Supply, as shipped, is wired for vehicles having the negative side of the battery grounded. If this equipment is to be installed in vehicles having the positive side grounded, make the wiring change noted in figure 18, schematic diagram of the Model PS-150-12 Power Supply.

Before installing the equipment, it is necessary to set the position of the connectors in the rear of the mounting rack. This may be accomplished as follows:

1. Set the mounting rack on a work bench with the rear of the rack on the bench and the side panels open. Make sure the four nuts securing the power and antenna connectors have been loosened.
2. Holding the transceiver with the front panel up, very carefully slide the transceiver into the rack until the power and antenna connectors mate with those in the mounting rack.

IMPORTANT

Extreme care must be exercised in performing this step to prevent damaging the connectors on the transceiver and in the mounting rack.

3. With the transceiver securely in position, turn the equipment on its side and tighten the four nuts holding the connectors in the mounting rack in place.
4. Carefully remove the transceiver from the mounting rack and proceed with the installation.

A base bracket and mounting straps are provided for installing the Model MR-150 Mounting Rack under the dashboard or on the transmission hump (see figure 4). When selecting a location for installing the mounting rack, an open area should be allowed on the top or bottom to provide adequate ventilation for the transceiver when it is in place.

The SR-150 Transceiver may be installed at this time if desired. Before installing the transceiver in the mounting rack, ascertain that the antenna switch on the rear panel is in the down (common) position. Slide the transceiver back into the MR-150 Mounting Rack so that a good connection is made to the power and antenna receptacles on the rear inside of the mounting rack. Secure the units together by means of the wing screws on both sides of the mounting rack.

The Model PS-150-12 Power Supply may be installed in any convenient location. In the installation discussed in this book, the power supply will be installed in the trunk (see figure 5). Mount the power supply securely, using self-tapping screws. Position the power supply in such a

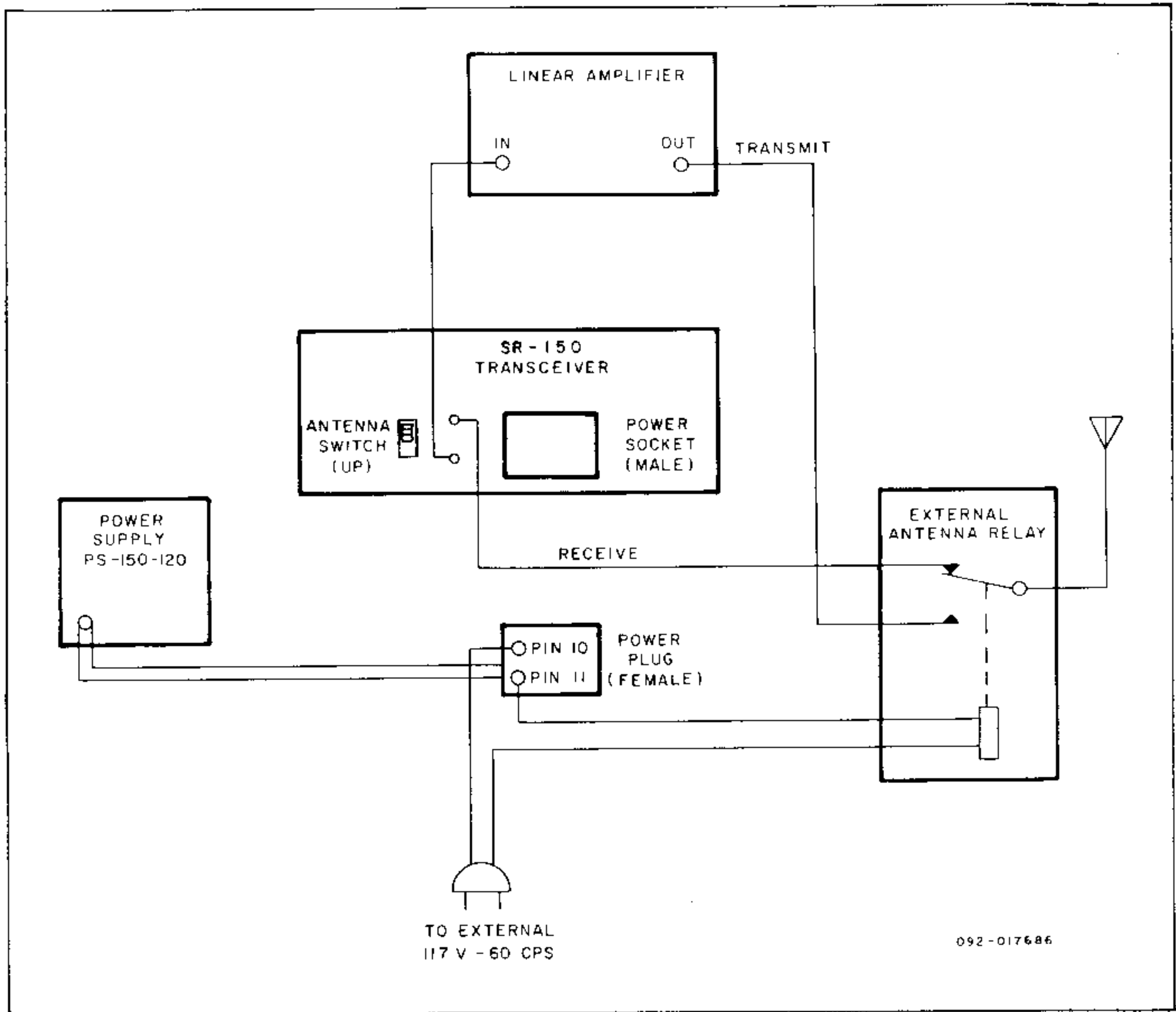

Figure 3. Base Installation Using a Linear Amplifier.

manner that the side with the terminal strips is accessible. Run the cable from the mounting rack under the floor mat and under the rear seat into the trunk. Since this cable is weatherproof, it may be threaded underneath the vehicle if desired. Cut the cable to the desired length, strip the wires, and connect these wires to the terminal strip on the power supply (see figures 5 and 17 for color coding and terminal numbering).

IMPORTANT

Before connecting to the vehicle's battery, check the transceiver, if already installed, to ascertain that the OPERATION switch is in the OFF position.

Connect the two NO. 8 AWG wires supplied between the two-connector terminal strip on the power supply and the battery. The red/white wire

should be connected from the top terminal on the power supply to the positive (+) side of the battery and the red/black wire from the bottom terminal to the negative (-) side of the battery. These wires should be cut to a suitable length before being connected to the battery. The positive lead should be connected to the battery through a 30-ampere fuse block (not supplied, see figure 5). If the vehicle has a positive ground electrical system, fuse the negative lead.

CAUTION

USE CARE WHEN MAKING CONNECTIONS TO THE BATTERY IN THE VEHICLE. THE POWER IN A BATTERY CAN CAUSE DANGEROUS BURNS AND EVEN EXPLOSION IF SHORT CIRCUITED.

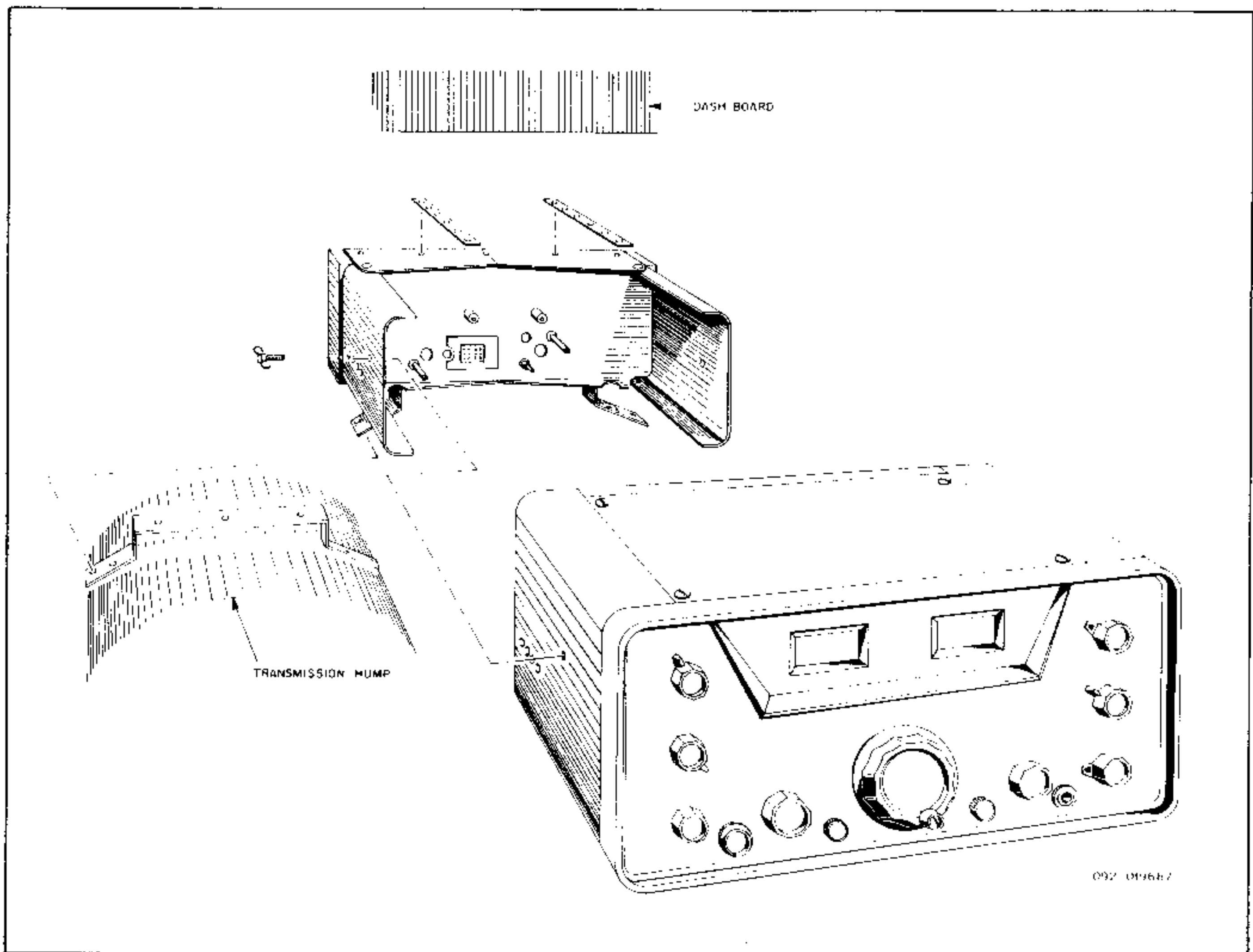

Figure 4. Installing the Model MR-150 Mounting Rack.

Connect the speaker to the jack provided on the side of the mounting rack. This jack accepts a standard PL55 type plug.

Use of the auto radio loud speaker is not recommended unless a switch is installed to remove the speaker from the auto radio when operating the SR-150.

Install the antenna in the manner recommended by the antenna manufacturer. Connect the coaxial cable from the antenna, through the hole in the right side of the mounting rack, and solder to the rear of the phono-pin-plug type connector in the rear of the mounting rack. Use care when soldering. Solder on the outside of the center pin must be removed to prevent possible damage to the female antenna connector in the transceiver. If desired, prior to installing the mounting rack, a length of coaxial cable may be connected from this phono-pin-plug type connector to a coaxial connector attached to the right side of the mounting rack in the space provided. If this is done, when the antenna is installed, it may be attached to the connector using a mating connector.

Connect a suitable microphone to the jack provided on the front panel. It is important that the internal wiring of the microphone be as shown in figure 6.

IMPORTANT

Before proceeding, refer to alignment procedure, paragraph 8-3, for bias adjustment.

Only after familiarizing yourself with the controls and their functions, as outlined in Sections IV and V, should you perform an operational check. It is recommended that the engine be running while operating the Model SR-150 Transceiver to prevent draining power from the battery.

3-5. MOBILE NOISE SUPPRESSION.

The following suggestions may be helpful in the suppression of noise encountered in mobile operation. Install resistor-type spark plugs and

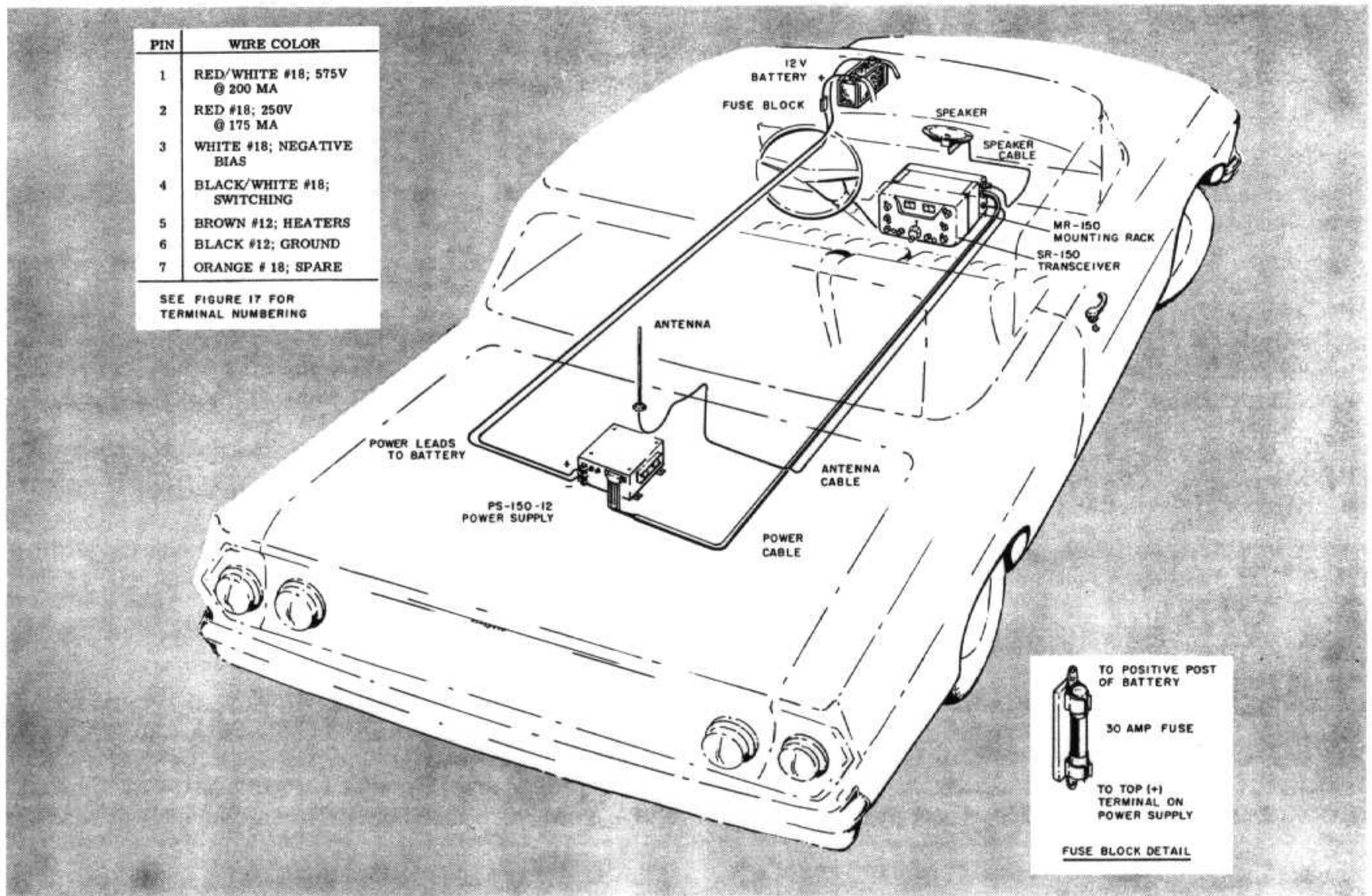

Figure 5. Wiring Diagram of Mobile Installation.

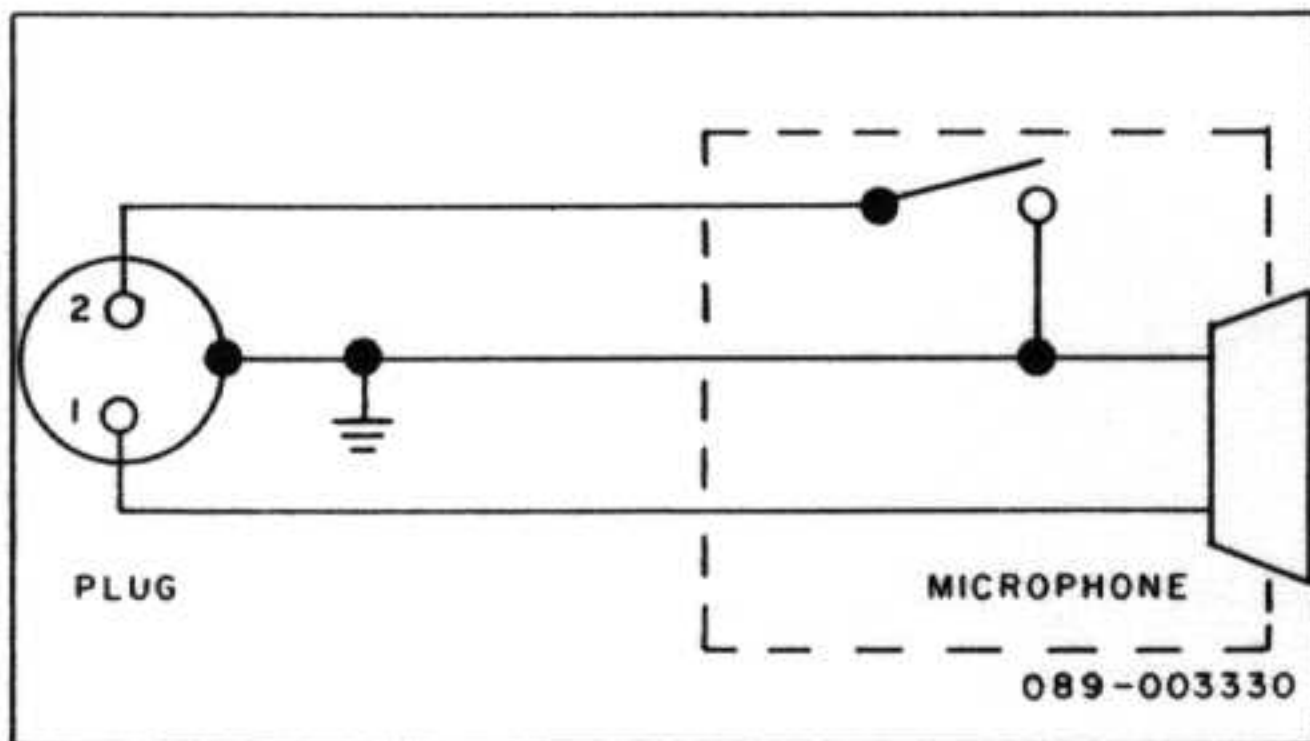

Figure 6. Required Microphone Wiring.

coaxial bypass capacitors in the ignition coil, generator, and voltage regulator leads. Install bracket-mounted coaxial capacitors in the generator and battery leads to the voltage regulator and connect a 0.005 microfarad mica or disc capacitor from the generator lead to ground. Chokes may be used in the generator field and armature leads instead of the bypass capacitors — approximately 12 turns of NO. 18 wire on a 1/4-inch powdered iron core for the field lead choke and approximately 12 turns of NO. 12 or NO. 14 wire on a 1/4-inch powdered iron core for the armature lead choke.

Hallicrafters has available a Mobile Noise Suppression Kit, Model HA-3, which will fulfill any suppression requirements of this installation.

Additional information, concerning the proper suppression of mobile noise, is available in the Handbook of Instructions for Hallicrafters' Model HA-3 Mobile Noise Suppression Kit and in other current handbooks on the same subject.

3-6. BASE INSTALLATION.

The Model SR-150 Transceiver, as a base station, may be used with or without a linear amplifier. To operate from 117 volts AC, the Model PS-150-120 Power Supply, or an equivalent, is required. Merely connect the power plug from the power supply to the receptacle on the rear of the transceiver, connect the AC cord from the power supply to the wall outlet, and connect to an antenna installation as described in paragraph 3-3. A four by six inch speaker is contained in the power supply and is interconnected to the transceiver through the power plug.

IMPORTANT

Before operating the SR-150, the bias adjustment control on the power supply must be set. See paragraph 8-3 of the alignment procedure.

If a linear amplifier and an antenna change-over relay are used, the cap on the plug of the power supply cable must be loosened, enabling

wires to be soldered to pins 10 and 11 of the plug (see figure 3), thus providing a control circuit for the relay.

SECTION IV

FUNCTION OF OPERATING CONTROLS

All controls utilized during normal operation of Hallicrafters Model SR-150 Transceiver are located on the front panel (see figure 7).

4-1. RIT CONTROL — ON/OFF.

The Receiver Incremental Tuning (RIT) control is made up of two controls with concentric shafts. The ON/OFF function of the lever control either puts the variable-element RIT control in or out of operation. This control, in the ON position, enables the operator to fine-tune the receiver plus or minus two KC by means of the RIT potentiometer (round knob) without disturbing the initial calibration or transmitting frequency. Returning the control to the OFF position locks the receiver frequency to the transmitter frequency.

4-2. RF GAIN — AF GAIN.

The RF GAIN and AF GAIN controls are two controls mounted on concentric shafts. The RF

GAIN control (lever control) varies the gain of the receiver RF amplifier and mixer. Maximum sensitivity is obtained with the control set at 10 (fully clockwise).

The AF GAIN control (round knob) adjusts the audio output level at the speaker terminals and PHONES jack. Clockwise rotation increases the signal applied to the grid of the audio amplifier, thus increasing the audio output.

4-3. OPERATION.

The OPERATION control is a four-position switch. In the OFF position, all power is disconnected from the circuitry. In the STBY position, the receiver portion of the unit is in operation and all circuits common to both receiver and transmitter are in the receive condition. In this position, those functions used only in the transmit mode are biased off. In the MOX (push-to-talk) position, the transmitter portion of the unit is in operation and all circuits common to both transmitter and receiver are in the transmit condition.

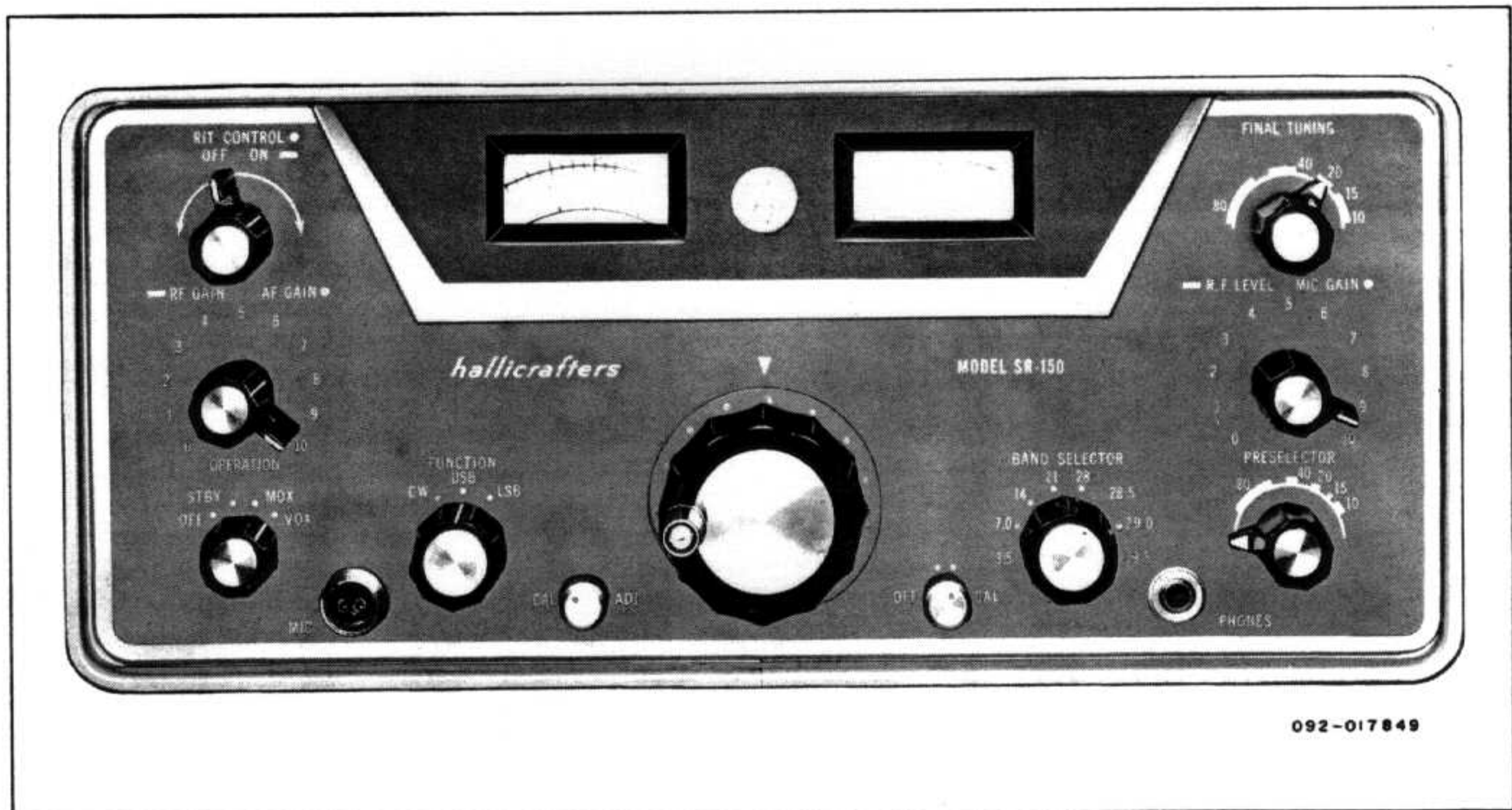

Figure 7. Front Panel View of Transceiver.

In this position, those circuits used only in the receive mode are automatically biased off when the transmitter is keyed (microphone button depressed). In the VOX position, the transmitter is energized by voice or part of the first character of a CW transmission. In the absence of voice or keying, the unit is automatically placed in the receive mode. This portion can also be referred to as Automatic.

4.4. FUNCTION.

The FUNCTION control is a three-position switch. This switch is used to select the mode of operation: CW, LSB, or USB.

4.5. CALIBRATION ADJUSTMENT (CAL ADJ).

The CAL ADJ control varies the frequency of the Variable Frequency Oscillator (VFO) over a small range so that its frequency can be set precisely when compared to a standard.

4.6. OFF - CALIBRATE (CAL).

The OFF-CAL control is a two-position switch used to turn the crystal calibrator off or on. When in the CAL or on position, it provides standard frequencies at 100-KC intervals to accurately calibrate the VFO.

4.7. BAND SELECTOR.

The BAND SELECTOR control is an eight-position switch used to select the desired band for receiving or transmitting. This control also indicates the low-frequency end of the band and which scale, red or black, to read on the dial for direct frequency determination.

4.8. TUNING (VFO).

The TUNING control tunes in the frequency to which you are listening. As an added feature, the position of this knob may be adjusted by using

the bristol wrench supplied. Loosen the two set screws and position the TUNING knob on the shaft against the felt pad for the desired amount of drag or torque.

4.9. PRESELECTOR.

The PRESELECTOR tunes to the desired frequency within a given band, as indicated by the setting of the BAND SELECTOR. The function of the PRESELECTOR, however, is determined by the OPERATION control. With the OPERATION control in the STBY position, the PRESELECTOR tunes the receiver RF and first mixer stages; with the OPERATION control in the MOX or VOX position, the PRESELECTOR tunes the transmitter mixer and driver stages.

4.10. RF LEVEL - MIC GAIN.

The RF LEVEL and MIC GAIN controls are two controls mounted on concentric shafts. The RF LEVEL control (lever control) varies the output of the transmitter mixer, thereby varying the RF output. Maximum drive to the output stages is obtained with the control set at 10 (fully clockwise). The RF LEVEL control functions only in the CW mode of operation.

The MIC GAIN control (round knob) varies the audio level from the microphone amplifier stages to the balanced modulator. The control has sufficient range to permit adjustment of any high-level crystal microphone or low-level dynamic microphone normally used for voice communication.

4.11. FINAL TUNING.

The FINAL TUNING control consists of a continuously tunable capacitor with a band-segment indicator. This control tunes the final output stage to the operating frequency.

SECTION V TUNING PROCEDURE

5.1. GENERAL.

The tuning procedure of the Model SR-150 Transceiver is not complicated; however, care should be exercised when tuning to insure peak performance of the equipment. The following paragraphs describe the procedures for receiver and transmitter tuning.

IMPORTANT

Before operating the SR-150, the Bias Adj. control on the power supply must be set. See paragraph 8-3 of alignment procedure.

5.2. RECEIVER CALIBRATION.

Preset the controls as indicated:

OPERATION	STBY (receive, power on)
RF GAIN	Maximum
AF GAIN	As required
FUNCTION	Desired sideband
BAND SELECTOR . . .	Desired band
TUNING	100-KC point nearest desired frequency

PRESELECTOR Desired band segment
 RIT OFF
 CAL CAL (on)
 CAL ADJ As required

To calibrate, set the TUNING control to the 100-KC point on the dial nearest the desired frequency. Rotate the CAL ADJ control for zero beat. It may be necessary to increase the AF GAIN control to get sufficient indication at or near zero beat. The RIT control switch must be in the OFF position when calibrating. Turn the CAL switch to OFF and tune to the desired frequency. Peak the PRESELECTOR control for maximum S-meter indication.

NOTE

The CAL switch should be in the OFF position in normal use of the receiver. It should be in the CAL position only when calibrating the receiver.

5.3. BASIC TUNE-UP.

Preset the indicated controls as follows:

OPERATION MOX
 FINAL TUNING Desired band segment
 FUNCTION CW
 BAND SELECTOR Desired band
 TUNING Desired frequency
 PRESELECTOR Desired band segment
 RF LEVEL Between 4 and 5, or as required.

Adjust the RF LEVEL control until a small indication is seen on the S-meter. In the transmit mode, the S-meter indicates relative RF output voltage. Adjust the FINAL TUNING control for maximum output and then adjust the PRESELECTOR for maximum output indication. Adjust the RF LEVEL control as required to keep the S-meter reading below S9, while tuning the PRESELECTOR.

5.4. MANUAL CW OPERATION.

Use the procedure as given in paragraphs 5-2 and 5-3. (If a key is plugged into the Key

jack, J5, it must be closed.) Advance the RF LEVEL control to just below saturated output.

Saturated output is determined in the following manner. Start at "0" setting of the RF LEVEL control and slowly increase the control (clockwise) while observing the S-meter. Set the control at a point where further rotation does not cause an appreciable increase in the S-meter reading. This is saturated output; operate slightly below this level.

The transmitter is now ready to key. To receive, it is necessary to turn the OPERATION switch to the STBY position.

5.5. BREAK-IN CW OPERATION.

Use the tuning procedure as given in paragraphs 5-2 and 5-3. Set the OPERATION switch to the VOX position. Adjust the delay control (see figure 12) for the desired drop-out delay; delay increases with clockwise rotation. The unit is now ready for break-in CW operation.

5.6. PUSH-TO-TALK SSB OPERATION (MOX).

Use the procedure given in paragraphs 5-2 and 5-3. Set the FUNCTION switch to the desired sideband (USB or LSB). Set the OPERATION switch to MOX. Depress the microphone switch (push-to-talk) and advance the MIC GAIN control (while speaking into the microphone in a normal voice level) until the S-meter indicates approximately one-half the level shown at saturation. The MIC GAIN setting is not critical, because of the action of the AALC circuitry, and may be advanced slightly beyond this point to increase compression. Typical settings will run from 5 to 8.

5.7. VOICE CONTROLLED SSB OPERATION (VOX).

For voice operated transmission, use the tuning procedure in paragraphs 5-2 and 5-3. Set the FUNCTION switch to the desired sideband (USB or LSB). Set the OPERATION switch to the VOX position. Set the receiver AF GAIN to "0" or a low level. While speaking into the microphone, advance the VOX gain control clockwise (see figure 12) until the VOX relay closes; use no more VOX gain than necessary. Adjust the delay control for the desired drop-out delay; delay time increases with clockwise rotation. It may be necessary to readjust the VOX gain slightly because of interaction between the controls. Adjust the receiver AF GAIN to the desired listening level. Advance the QT (anti-trip) control (see figure 12) clockwise until received signals do not actuate the VOX relay. Use no more anti-trip gain than necessary.

SECTION VI

THEORY OF OPERATION

6-1. GENERAL.

The Model SR-150 Transceiver consists of a double-conversion receiver and a double-conversion transmitter. The VFO circuitry, the heterodyne crystal oscillator circuitry, and the crystal filter/IF circuitry are common to both the transmitter and receiver. Refer to figure 8 for a block diagram of the equipment and to figure 21 for a schematic diagram.

6-2. RECEIVER CIRCUIT.

The signal at the antenna is applied to the receiver's RF amplifier stage (V1A) through the antenna relay located in the transmitter final amplifier section. This signal is amplified and then fed to a mixer (V2), where it is mixed with the signal from the heterodyne crystal oscillator (V8), resulting in a variable IF signal of 6.0 MC to 6.5 MC. The RF amplifier and mixer tuned circuits are selected by the BAND SELECTOR switch and tuned by the PRESELECTOR control.

The variable IF signal is amplified by a tunable IF amplifier (V3A) and then mixed with the signal from the VFO (variable frequency oscillator), V9, in the receiver mixer (V4), resulting in a second IF signal of 1650 KC. This signal is amplified by the first 1650-KC IF amplifier (V17A), passed through the crystal-lattice filter (FL1), and applied to the second 1650-KC IF amplifier (V5A). The output from V5A is fed to the product detector (V6) where it is mixed with the correct carrier oscillator output to present the desired detected sideband signal to the receiver first audio amplifier (V11A).

The output of the first audio amplifier is applied to the audio output stage (V13) and then to the speaker. The proper sideband is selected by a shift in the VFO frequency coupled with a selection of the proper carrier oscillator and the passage of the signal through the crystal-lattice filter, thereby rejecting the undesired sideband.

6-3. TRANSMITTER SECTION.

The signal from the microphone is applied through the first and second microphone amplifiers (V18A and V18B) and fed to an audio cathode follower (V3B). The output of V3B is presented to the balanced modulator along with the selected signal from the carrier oscillator (V10), to produce a double-sideband suppressed carrier signal.

The balanced modulator output signal is applied to the first 1650-KC IF amplifier (V17A), through the crystal-lattice filter (FL1) which attenuates the unwanted sideband, to the receiver and transmitter mixer (V2) where the signal is added to the VFO (V9) output signal. The sum of these signals (in the 6.0-MC to 6.5-MC range) is then amplified by the tunable IF amplifier (V3A) and fed to the transmitter mixer (V7) where it is subtracted from the heterodyne crystal oscillator (V8) signal.

The output of the transmitter mixer is the desired operating frequency and is amplified by the transmitter driver (V16) and then fed to the transmitter final amplifiers (V14 and V15). The selected final output signal is applied through the antenna relay to the antenna.

The tuned circuits of the transmitter mixer and transmitter driver are selected by the BAND SELECTOR switch and tuned by the PRESELECTOR control, while the final amplifier output tuned circuit is selected by the BAND SELECTOR switch and tuned by the FINAL TUNING control.

The Automatic Audio Level Control (AALC) circuitry operates in the following manner. When a small amount of flat-topping occurs in the final amplifier, an audio signal appears on the amplifier bias line, in proportion to the amount of flat-topping. This audio signal, which is not present without final amplifier flat-topping, is coupled to the AALC amplifier (V5B) whose output is rectified by diodes CR7 and CR8. The resulting DC voltage, which is in direct proportion to the amount of flat-topping occurring in the final amplifier, is connected to the 6.5-MC to 6.0-MC IF amplifier and the first 1650-KC IF amplifier as gain control bias.

SECTION VII

SERVICE DATA

7-1. COVER AND CHASSIS REMOVAL.

A. TOP COVER REMOVAL. - Loosen the four top-cover screws 1/4 turn only and remove cover. To replace cover, tighten cover screws 1/4 turn only, so that the plastic latch nuts will not be damaged.

B. BOTTOM COVER REMOVAL. - Remove the four bottom cover screws located in the feet, and remove the cover. When replacing the bottom cover, make certain that the grounding clip on the cover engages properly at the final amplifier shield partition.

C. CHASSIS REMOVAL. - To remove the chassis from the cabinet, it is first necessary to remove the bottom cover (see paragraph 7-1B). Remove the four cabinet screws at the bottom near the cabinet feet and carefully slide the chassis and panel assembly out from the front of the cabinet.

7-2. TUBE AND DIAL LIGHT REPLACEMENT.

Access to the dial light and all tubes may be obtained by removing the top cover of the cabinet. See paragraph 7-1A.

7-3. TROUBLESHOOTING.

In the design of this transceiver, full consideration was given to keep maintenance problems at an absolute minimum. As in all well-designed electronic equipment, maintenance and repair problems are generally confined to the checking and replacement of tubes and semiconductor devices which may become defective. Malfunctions of this nature are usually easily isolated and corrected. However, it is entirely possible that a more obscure malfunction may arise. In this event, only thoroughly trained technical personnel should attempt to service equipment of this complexity.

A recommended aid to troubleshooting the Model SR-150 Transceiver is a general-coverage receiver which can be used to provide a quick check on the various oscillator circuits within the SR-150. A lead connected to the antenna of this receiver, when placed in the proximity of the oscillator tube in the circuit to be checked, can determine the presence or absence of signal from the stage in question.

If a malfunction occurs when operating on one particular band and/or mode of operation, the unit should be checked on all other bands and in all other modes of operation to isolate the difficulty. A careful study of the block diagram (figure 8) will give a quick clue as to which tubes should be checked. The voltage and resistance charts (figures 9 and 10) and schematic diagram (figure 21) will also aid in isolating and correcting a malfunction.

7-4. SERVICE AND OPERATING QUESTIONS.

For further information regarding operation or servicing of the Model SR-150 Transceiver, contact the dealer from whom the unit was purchased. The Hallicrafters Company maintains an extensive system of Authorized Service Centers where any required service will be performed promptly and efficiently at no charge if this equipment is delivered to the service center within 90 days from date of purchase by the original buyer and the defect falls within the terms of the warranty. It is necessary to present the bill of sale in order to establish warranty status. After the expiration of the warranty, repairs will be made for a nominal charge. All Hallicrafters Authorized Service Centers display the sign shown below. For the location of the one nearest you, consult your dealer or your local telephone directory.

Make no service shipments to the factory unless instructed to do so by letter, as The Hallicrafters Company will not accept responsibility for unauthorized shipments.

The Hallicrafters Company reserves the privilege of making revisions in current production of equipment and assumes no obligation to incorporate such revisions in earlier models.



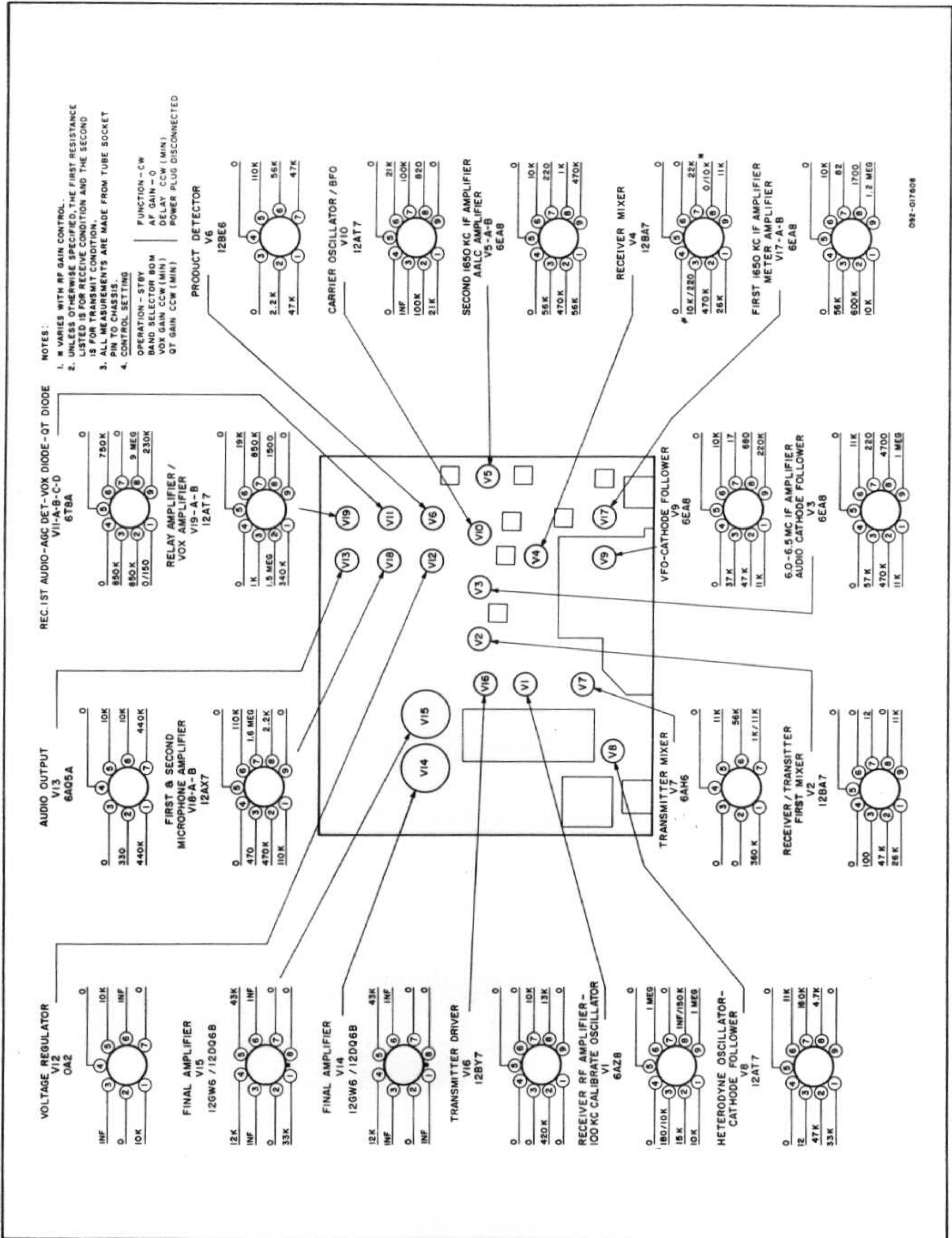

Figure 10. Resistance Chart.

SECTION VIII

ALIGNMENT PROCEDURE

8-1. GENERAL.

The Model SR-150 Transceiver has been accurately aligned and calibrated at the factory and, with normal usage, will not require re-alignment for extended periods of time. Service or replacement of a major component or circuit may require subsequent realignment, but under no circumstances should realignment be attempted unless the malfunction has been analyzed and definitely traced to mis-alignment. Alignment should only be performed by persons experienced in this work, using the proper test equipment.

NOTE

Do not make any adjustments unless the operation of this transceiver is fully understood and adequate test equipment is available. Refer to figures 11 and 12, the top and bottom views of the transceiver, for the locations of all adjustments.

8-2. EQUIPMENT REQUIRED.

1. RF Signal Generator; Measurements Corporation, Model 65B or an equivalent signal generator having up to 1 volt output at an impedance of 70 ohms or less (a 100 micro-microfarad DC blocking capacitor must be placed in series with the RF lead).
2. A Vacuum Tube Voltmeter (VTVM); Hewlett-Packard Model 410B, or equivalent VTVM having an RF probe good to 30 MC.
3. A Dummy Load; 50 ohms non-reactive, rated at 100 watts. Bird Wattmeter or equivalent. The load may be made up of carbon resistors totaling 100 watts dissipation.
4. A DC Voltmeter having a 2.5-volt or 3.0-volt scale for final plate current measurements when using the Model PS-150-120 Power Supply or a 0-300 MA DC milliammeter when using the Model PS-150-12 Power Supply.
5. A general-coverage receiver covering the frequency range from 3 MC to 30 MC with a 100-KC calibrator.

8-3. BIAS ADJUSTMENT.

The final amplifier bias must be properly set before any extensive checks are made on the transmitter portion of the SR-150.

When using the AC power supply (PS-150-120), proceed as follows. Before turning the transceiver on, connect a DC voltmeter to the two tip jacks on the power supply (see figure 14), positive to red and negative to blue. Set the voltmeter on a low scale (2.5 volts or 3.0 volts). There is a 10-ohm resistor across the tip jacks so that the meter will indicate 1 volt for 100 MA.

Set the OPERATION switch to STBY and allow the unit to warmup about 5 minutes. Then set the FUNCTION switch to USB or LSB, MIC GAIN to "0", and OPERATION switch to MOX. Plug in a microphone and press the microphone switch. Adjust BIAS ADJ control, R206 on the power supply, for 0.7 volt (70 MA plate current) on voltmeter.

When using the DC power supply (PS-150-12) the high voltage (red/white) lead must be disconnected from the power supply terminal strip (pin 1) and a DC milliammeter, having a full-scale deflection of not less than 300 MA, connected between the lead and the high voltage terminal on the power supply. Follow the procedure outlined in the preceding paragraph and set the BIAS ADJ control, R308 on the power supply, for 70 MA.

8-4. IF ALIGNMENT (1650 KC).

Connect the signal generator to pin 7 of V4 and tune it to 1650 KC. Set the OPERATION switch to STBY and the FUNCTION switch to USB or LSB. Increase the signal generator output until the S-meter shows a small indication and rock the signal generator frequency to the approximate center of the crystal-filter passband. The output level may be monitored at the speaker terminals with an appropriate output meter. A VTVM may be used to monitor the AGC level or the S-meter may be used to indicate IF output.

Adjust the top and bottom slugs of T3 and the slug of T6 for maximum. Reduce the signal generator output to keep the S-meter reading below S9, thus, preventing possible overload and inaccurate adjustments.

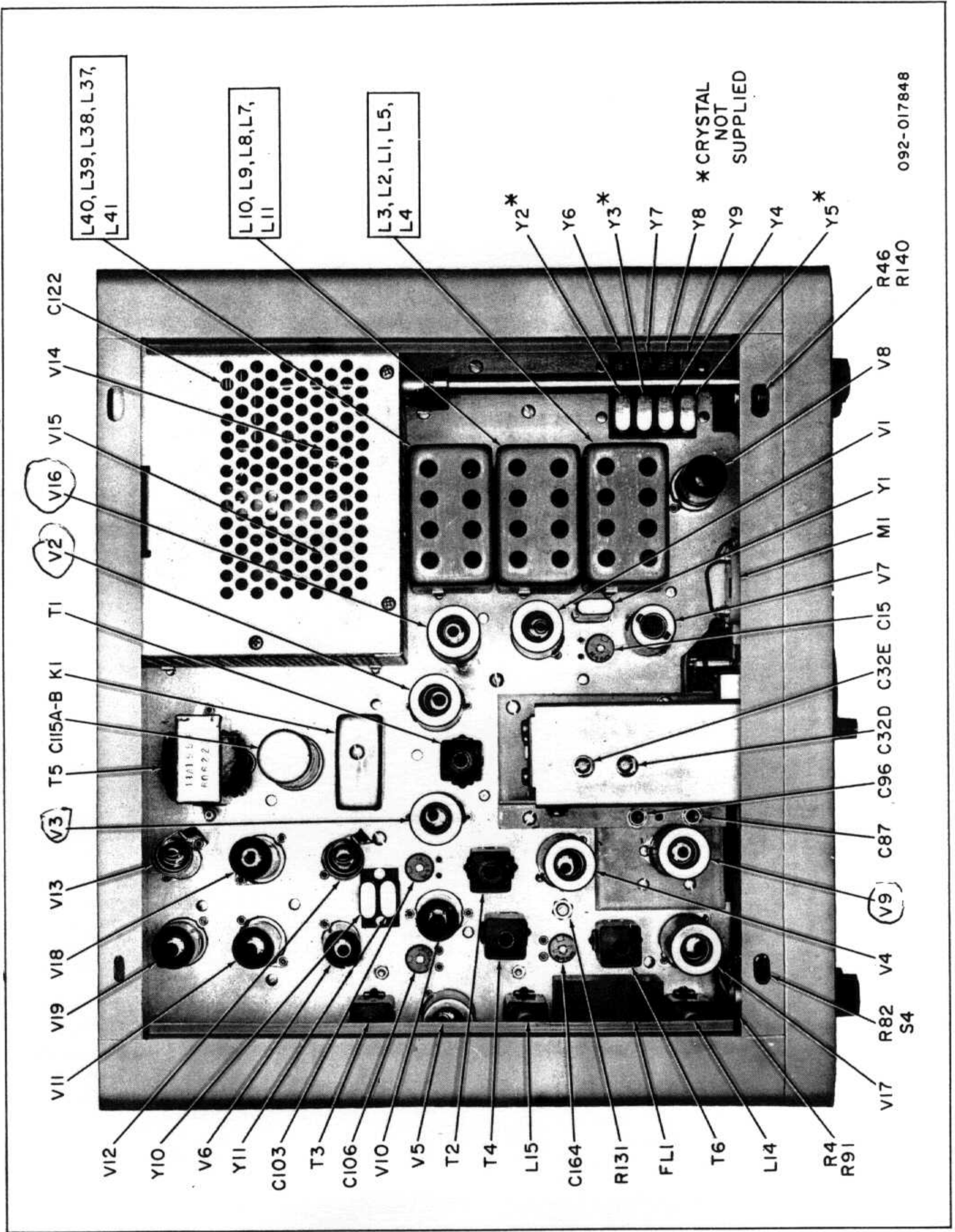
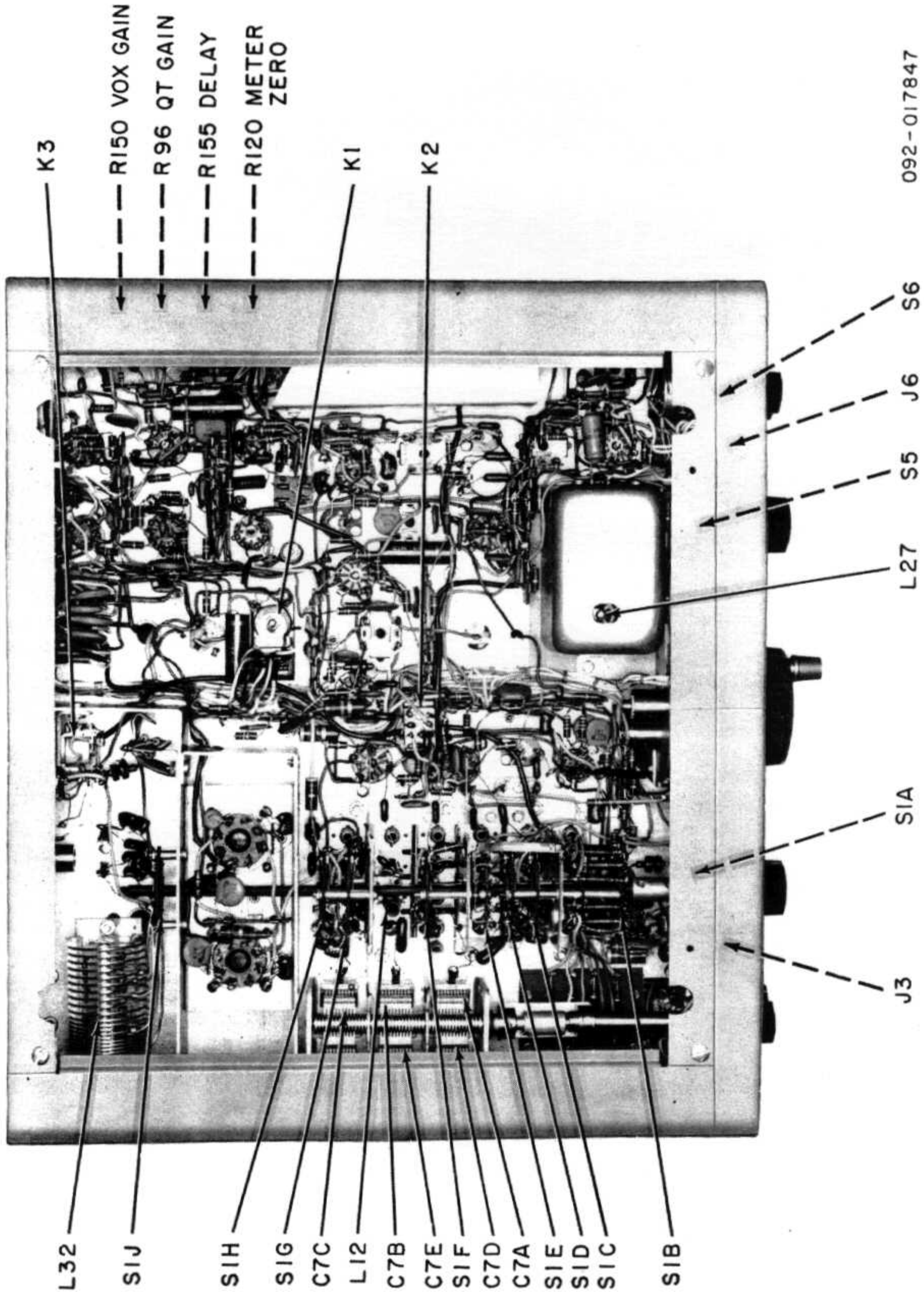

Figure 11. Top Chassis View of Transceiver.



092-017847

Figure 12. Bottom Chassis View of Transceiver.

8-5. CRYSTAL FILTER ALIGNMENT.

Because of the specialized techniques and test equipment required, it is recommended that realignment of the crystal-filter termination coils, L14 and L15, be handled through The Hallicrafters Company Service Department. However, the operation of the filter can be checked out as follows to determine whether or not the filter requires realignment.

1. Tune the transmitter into a 50-ohm load and switch to lower sideband (LSB).
2. With an audio generator connected to the microphone input at 1000 CPS, adjust the transmitter output for S9 on the S-meter.
3. Set the audio generator frequency to 600 CPS and the transmitter output should drop no more than approximately 3 DB, or to S7 on the S-meter.
4. Set the audio generator frequency to 2700 CPS and the transmitter output should drop no more than approximately 3 DB, or to S7 on the S-meter.

If the response of the transmitter does not meet these requirements, the SR-150 Transceiver should be returned for filter realignment.

8-6. IF ALIGNMENT (6.0 TO 6.5 MC).

Connect the signal generator to pin 2 of V2. Set the OPERATION switch to STBY (receive) and tune the VFO (TUNING control) to the low-frequency end of the dial (black 0, red 500). Set the signal generator to 6.5 MC and adjust trimmers C32D and C32E, located on the top of the center and rear sections of the VFO TUNING capacitor, for maximum receiver output. Keep the signal level low to prevent overload. Set the signal generator to 6.0 MC and tune the VFO to the high end of the dial (black 500 and red 1000). Tune the slugs of the IF transformers, T1 and T2, for maximum output, reducing signal generator output as required to prevent overload. Repeat adjustments of C32D, C32E, T1, and T2 until tracking is accomplished.

8-7. RECEIVER RF ALIGNMENT.

Connect the signal generator to the antenna jack, J1, at the rear of the chassis. Set the antenna switch to the receive only (up) position.

Set the OPERATION switch to STBY (receive), RF GAIN to maximum, AF GAIN as required, BAND SELECTOR to 29.5, and the PRESELECTOR to slightly above the high-frequency or right-hand edge of the 10-meter segment.

Tune the signal generator to 30.0 MC and tune the VFO to the high end (black 500). Tune the signal in and adjust trimmers C7D and C7E for maximum output, reducing signal generator output as required. Tune the signal generator to 28.0 MC. Set the PRESELECTOR to the low-frequency edge of the 10-meter segment, the BAND SELECTOR to 28, and tune the VFO to the low end of the dial (black 0). Tune the signal in and adjust the slugs of coils L5 and L7 for maximum output. Repeat the adjustments of C7D, C7E, L5, and L7 until tracking is accomplished.

Tune the signal generator to 21.3 MC and set the BAND SELECTOR to 21. Tune the VFO to 300 on the dial. Tune in the signal and adjust the slugs of coils L1 and L8 for maximum output.

Tune the signal generator to 14.3 MC and set the BAND SELECTOR to 14. Tune the VFO to 300 on the dial. Tune in the signal and adjust the slugs of coils L2 and L9 for maximum output.

Tune the signal generator to 7.3 MC and set the BAND SELECTOR to 7. Tune the VFO to 300 on the dial. Tune in the signal and adjust the slugs of coils L3 and L10 for maximum output.

Tune the signal generator to 3.8 MC and set the BAND SELECTOR to 3.5. Tune the VFO to 300 on the dial. Tune in the signal and adjust the slugs of coils L4 and L11 for maximum output.

8-8. 6.5-MC TRAP ADJUSTMENT.

With the signal generator connected to the antenna jack (J1), at the rear of the chassis, tune the signal generator to 6.5 MC. Set the BAND SELECTOR to 7.0 and tune the VFO to the low end of the dial (black 0). Tune the signal in and adjust the slug of coil L12 (6.5-MC trap) for minimum output.

NOTE

A slight readjustment of the 40-meter RF coil slug, L10, may be required after the 6.5-MC trap, L12, is tuned.

8-9. DRIVER PLATE CIRCUIT RF ALIGNMENT.

After the final amplifier bias has been properly adjusted (see paragraph 8-3) and the receiver alignment has been completed (see paragraphs 8-4 through 8-8), the driver plate circuit coils may be aligned.

Connect a 50-ohm to 52-ohm resistive load to the antenna jack, J2. Set the OPERATION switch to STBY (receive) and the FUNCTION switch to CW. Set the BAND SELECTOR to 28.5 and the VFO to 300 on the dial. Set the FINAL

TUNING to the 10-meter segment. Turn the CAL switch to ON and tune the calibrator signal in at 28.8 MC. Adjust the PRESELECTOR for maximum S-meter indication. Set the OPERATION switch to MOX and advance the RF LEVEL control until a small indication is noted on the S-meter. Adjust the FINAL TUNING for maximum output. Do not change the setting of the PRESELECTOR. Adjust the slug of coil L37 for maximum output (S-meter indication), reducing the setting of the RF LEVEL control as required to keep the output at a low value to prevent flat-topping.

Repeat the above paragraph for each band, referring to the tuning chart for the appropriate settings and adjustments.

TRANSMITTER DRIVER TUNING CHART

Band	FINAL TUNING Adjust for Maximum Output	PRESELECTOR Tuned In Receiver on 100-KC Marker	Adjust Coil for Maximum Output in Transmit
29.5	10	-	-
29.0	10	-	-
28.5	10	28.8 MC	L37
28.0	10	-	-
21.0	15	21.3 MC	L38
14.0	20	14.3 MC	L39
7.0	40	7.3 MC	L40
3.5	80	3.8 MC	L41

8-10. FINAL AMPLIFIER NEUTRALIZATION.

The final amplifier may be neutralized as follows. Tune the transmitter up on 21.3 MC (15-meter band) in CW function. This should be done with a meter in the high voltage line to read final plate current. (See paragraph 8-3 for meter insertion.) Adjust the RF output level to about 50 volts or about 30 on the S-meter with the RF LEVEL control. Carefully tune the FINAL TUNING and observe the plate current dip and the output voltage peak. If both occur at the same setting, the amplifier is neutralized. If both do not occur together, adjust the neutralizing capacitor, C139, in small increments (1/4 to 1/2 turn) until neutralization is accomplished.

8-11. CARRIER BALANCE.

Tune the transmitter up on 3.8 MC (80-meter band) in CW function into a dummy load. Switch to upper sideband (USB on FUNCTION switch) and adjust capacitor, C164, and potentiometer, R131, for minimum RF output. An RF voltmeter with a one-volt scale at the dummy load can be used to indicate minimum output. If a voltmeter is not available, a receiver tuned to the carrier frequency may be used to indicate carrier balance.

8-12. BFO / CARRIER OSCILLATOR OUTPUT TRANSFORMER ALIGNMENT.

Connect an RF voltmeter to pin 7 of V6 (product detector). Adjust the slug of T4 for approximately 7.0 volts at the product detector (grid 3). This adjustment must be made on the high frequency side of the peak setting of the transformer; that is, turning the slug counter-clockwise from peak output.

NOTE

This adjustment should not be attempted unless T4 has been replaced, as it has an effect on carrier oscillator frequency.

8-13. BFO / CARRIER OSCILLATOR FREQUENCY ADJUSTMENT.

The BFO/carrier oscillator frequency has been accurately set at the factory. The settings of the two warping trimmers, C103 and C106, should not be changed.

In the event that replacement of one of the VFO/carrier crystals, Y10 or Y11, is required, the VFO corrector trimmer may require re-adjustment. See paragraph 8-14 for procedure.

8-14. VFO CORRECTOR.

The VFO corrector trimmer, C96, shifts the VFO frequency approximately 3600 CPS to correct for the difference in frequency between the upper and lower sideband BFO/carrier crystals. The trimmer is switched into the VFO circuit in upper sideband. It is set in the following manner. With the receiver in lower sideband, tune the 100-KC calibrator signal to zero beat at 3.8 MC. Switch to upper sideband and there should be less than a 5 CPS change in frequency. If the change is greater, carefully adjust the trimmer (C96, on the VFO assembly) until the frequency change between sidebands is less than 5 CPS.

8-15. CRYSTAL CALIBRATOR ADJUSTMENTS.

The crystal calibrator trimmer is used to set the internal 100-KC crystal exactly to frequency by comparison to a signal transmitted by WWV.

With another receiver, tune-in WWV and connect a lead between the SR-150 antenna connector and the antenna connection of the external receiver. Turn the calibrator on in the SR-150 and carefully adjust the calibrator trimmer, C15, until the 100-KC oscillator harmonic is in zero beat with WWV.

NOTE

This adjustment should be made only during periods of NO modulation on station WWV.

8-16. VFO CALIBRATION ALIGNMENT.

If the electrical index check at the 100-KC check points on all bands shows that the calibration marks consistently fall to one side of the pointer, a trimmer adjustment is indicated. (This will be necessary only if the calibration is beyond tuning range of the CAL ADJ control.)

Proceed as follows:

- a. Adjust the TUNING control until the dial is at 500 (3.5 MC).
- b. Set the BAND SELECTOR at 3.5, FUNCTION to USB, and CAL-OFF to CAL.
- c. Carefully adjust trimmer C87 in very small increments until a zero beat is heard. Care should be exercised to make sure that the correct 100-KC beat note is tuned-in with the trimmer.
- d. Check across the dial at the 100-KC check points. If the frequency error is less than 3000 CPS, the calibration is within acceptable limits. If the error at the high-frequency end of the dial (4.0 MC) is greater than 3000 CPS, the VFO may require a coil adjustment in addition to the trimmer adjustment.

8-17. CONDITIONS REQUIRING COIL AND TRIMMER ADJUSTMENT.

If the dial error progressively increases in the same direction with the high-frequency end, running out more than 3000 CPS, at this end, both L27 and C87 should be adjusted.

- a. Adjust the TUNING dial to 1000 (4.0 MC) and adjust L27 to zero beat.
- b. Adjust the TUNING dial to 500 (3.5 MC) and adjust C87 to zero beat.
- c. Repeat steps a and b until both 3.5 MC and 4.0 MC are exactly on frequency.
- d. Check across the dial at the 100-KC points. If the frequency error is less than 3000 CPS, the calibration is within acceptable limits. If the error is in excess of 3000 CPS at any of the mid-points, with the end limits at zero error, the VFO capacitor (C32A) should be knifed. This operation should not be attempted by other than qualified personnel thoroughly familiar with the technique.

SECTION IX

AC POWER SUPPLY MODEL PS-150-120



Figure 13. Hallicrafters Model PS-150-120 AC Power Supply.

9-1. DESCRIPTION.

Hallicrafters' Model PS-150-120 Power Supply is a complete, self-contained power unit designed to permit Hallicrafters' Model SR-150 Transceiver to be operated from a nominal 117-volt AC source. This power supply, through a 12-pin power plug and cable at the rear, will furnish all the supply voltages necessary for optimum performance of the SR-150.

Hallicrafters' Model PS-150-120 operates from a 105-volt to 125-volt, 50/60-cycle, AC source. The power supply also contains a 3.2-ohm permanent-magnet type speaker which connects to the SR-150 through the 12-pin power plug and cable.

9-2. BIAS ADJUSTMENT.

After connecting the power supply to the SR-150 and to the proper power source, the transmitter bias must be adjusted to achieve optimum performance of the transceiver.

1. Connect a voltmeter to the tip jacks at the top rear of the power supply chassis. (Connect the positive lead from the meter to the red jack.)
2. Turn the Model SR-150 on: OPERATION switch to MOX - FUNCTION switch to USB.
3. With no signal applied to the transmitter, adjust the BIAS ADJ potentiometer, R206 on the rear of the power supply chassis, for 0.7 volt on the meter.
4. Disconnect the meter.

This adjustment is not necessary each time the SR-150 is used; however, it should be checked periodically and whenever the transmitter driver and/or final amplifier tubes are replaced.

9-3. CHASSIS REMOVAL.

To remove the PS-150-120 chassis from its cabinet, remove the six hex-head screws on the bottom (four are in the feet and two are at the center front and rear) and disconnect the speaker leads on the top rear of the chassis. The chassis will slide out the rear of the cabinet.

REPAIR PARTS LIST

Schematic Symbol	Description	Hallicrafters Part Number
C201,202	Capacitor, 0.01 μ F, 1400V, Ceramic Disc	047-200752
C203	Capacitor, 0.001 μ F, 3000V, Ceramic Disc	047-100397
C204A&B	Capacitor, 2 x 30 μ F, 350V, Electrolytic	045-000902
C205,206	Capacitor, 8 μ F, 450V, Electrolytic	045-000369
C207,208	Capacitor, 20 μ F, 250V, Electrolytic	045-000903
CR201,202, 203,204	Diode, Silicon, Type 1N3487	027-000314
CR205	Diode, 1N3194	019-002769
F201	Fuse, 3 Amperes, 125 Volts, 3AG, (Slow Blow)	039-100390
J201	Connector, Power (12-pin)	010-002613
L201	Choke, Filter	056-000595
L202	Choke, Filter	056-000585
L203	Choke, Filter	056-000501
R201,202	Resistor, 15K Ohms, 10%, 10 watts, Wire Wound	445-032153
R203	Resistor, 100 Ohms, 10%, 1/2 watt, Carbon	451-252101
R204	Resistor, 4700 Ohms, 10%, 2 watts, Carbon	451-652472
R205	Resistor, 10K Ohms, 10%, 1 watt, Carbon	451-352103
R206	Resistor, Variable, 10K Ohms, 20%, 3/4 watt, Bias Adj.	025-001833
R207	Resistor, 10 Ohms, 5%, 1 watt, Carbon	451-351100
T201	Transformer, Power	052-001007
TP201	Tip Jack, Red	036-000304
TP202	Tip Jack, Blue	036-000307
	Baffle Board	078-001711
	Baffle, Felt	014-000476
	Cabinet	066-003437
	Cable (9-conductor)	087-007657
	Cable Assembly	087-007648
	Cable Clamp	076-202746
	Foot, Plastic (4)	016-201072
	Front Panel	068-001263
	Fuse Holder	006-200837
	Line Cord	087-104690
	Lock, Line Cord	076-100953
	Rear Panel	068-001404
	Speaker, 4 x 6 inch PM, 3.2 Ohms	085-000218

SECTION X

DC POWER SUPPLY MODEL PS-150-12

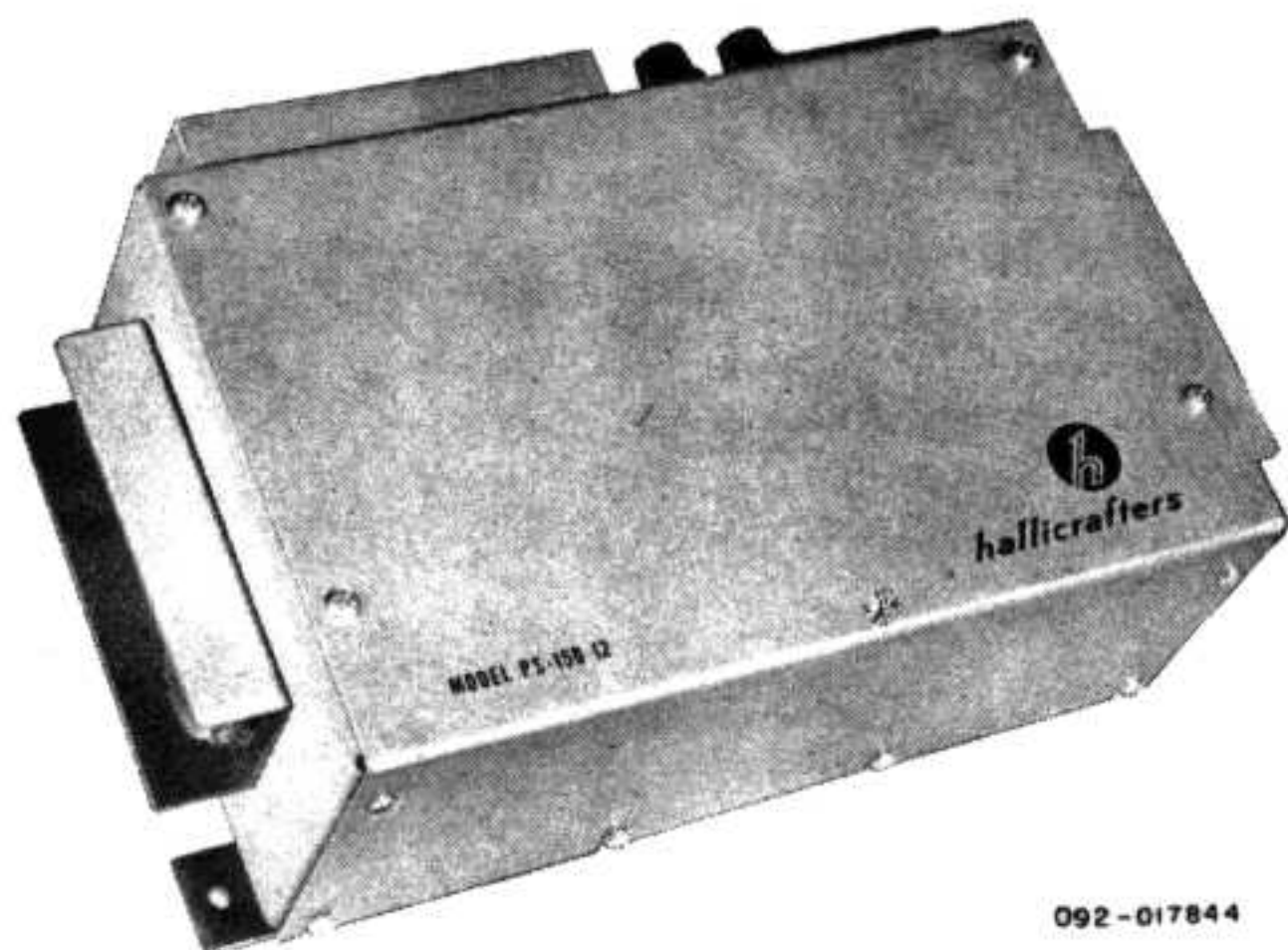

Figure 16. Hallicrafters Model PS-150-12 DC Power Supply.

10-1. DESCRIPTION.

Hallicrafters' Model PS-150-12 Power Supply is a complete, compact, self-contained power unit designed to permit Hallicrafters' Model SR-150 Transceiver to be operated from a nominal 12-volt DC source. This power supply is shipped for operation in conjunction with a negative-grounded power source. However, it is operable with a positive grounded source by changing two internal soldered connections as described in figure 15.

The Model PS-150-12 Power Supply, through interconnection with the Model MR-150 Mobile Mounting Rack, will furnish all the supply voltages necessary for optimum performance of the SR-150.

All connections are made to the power supply through two terminal strips on one side of the unit (see figures 5 and 17). The two-connector strip (TS301) is used for connection to the 12-volt source through the wires supplied. The seven-connector strip (TS302) is used to supply the operating voltages to the transceiver and connects to the mounting rack through the cable supplied with the mounting rack.

10-2. BIAS ADJUSTMENT.

After interconnecting the power supply to its proper power source and to the transceiver, the transmitter bias must be adjusted to achieve optimum performance of the transceiver.

1. Disconnect the high voltage (red/white) lead from pin 1 of TS302.

2. Connect an ammeter, with a full-scale deflection of 0-300 MA, between the high voltage lead and pin 1 of TS302.
3. Turn the transceiver on: OPERATION switch to MOX - FUNCTION switch to USB.
4. With no signal applied to the transceiver, adjust the BIAS ADJ potentiometer, R308 on the side of the power supply chassis, for a reading of 70 MA on the meter.
5. Disconnect the meter and reconnect lead to pin 1 of TS302.

This adjustment is not necessary each time the SR-150 is used; however, it should be checked periodically and whenever the transmitter driver and/or final amplifier tubes are replaced.

10-3. COVER REMOVAL.

Remove the nine screws on the top and one side of the unit and lift the cover off. This will provide easy access to all the components in the power supply.

REPAIR PARTS LIST

Schematic Symbol	Description	Hallicrafters Part Number
C301	Capacitor, 25 μ F, 50V, Electrolytic	045-000863
C302	Capacitor, 0.001 μ F, 3000V, Ceramic Disc	047-100397
C303,304,306	Capacitor, 40 μ F, 450V, Electrolytic	045-000904
C305	Capacitor, 0.22 μ F, 10%, 600V, Mylar	046-001376
C307,308	Capacitor, 20 μ F, 250V, Electrolytic	045-000903
CR301,302,303,304	Diode, Silicon, Type 1N3487	027-000314
CR305	Diode, Type 1N3194	019-002769
F301	Fuse, 15 Amperes, 23 Volts, 3AG	039-000707
F302	Fuse, 7.5 Amperes, 32 Volts, 3AG	039-000706
K301,302	Relay	021-000671
L301	Choke, Filter	056-000555
Q301,302,303,304	Transistor, Type 2N441	112-000194
R301	Resistor, 7.5 Ohms, 10%, 10 watts, Wire Wound	445-032075
R302	Resistor, 220 Ohms, 10%, 2 watts, Carbon	451-652221
R303	Resistor, 100 Ohms, 10%, 7 watts, Wire Wound	445-022101
R304	Resistor, 100 Ohms, 10%, 1/2 watt, Carbon	451-252101
R305	Resistor, 1000 Ohms, 10%, 1/2 watt, Carbon	451-252102
R306,307	Resistor, 4.7K Ohms, 10%, 2 watts, Carbon	451-652473
R308	Resistor, Variable, 10K Ohms, 20%, 3/4 watt, Bias Adj.	025-001833
R309	Resistor, 10K Ohms, 10%, 1 watt, Carbon	451-352103
T301	Transformer, Power	052-000969
	Cabinet Cover	066-003454
	Cable Clamp	076-202744
	Clamp, Resistor (R301)	076-004121
	Cover, Terminal Strip (TS302)	066-003574
	Fuse Holder	006-200837

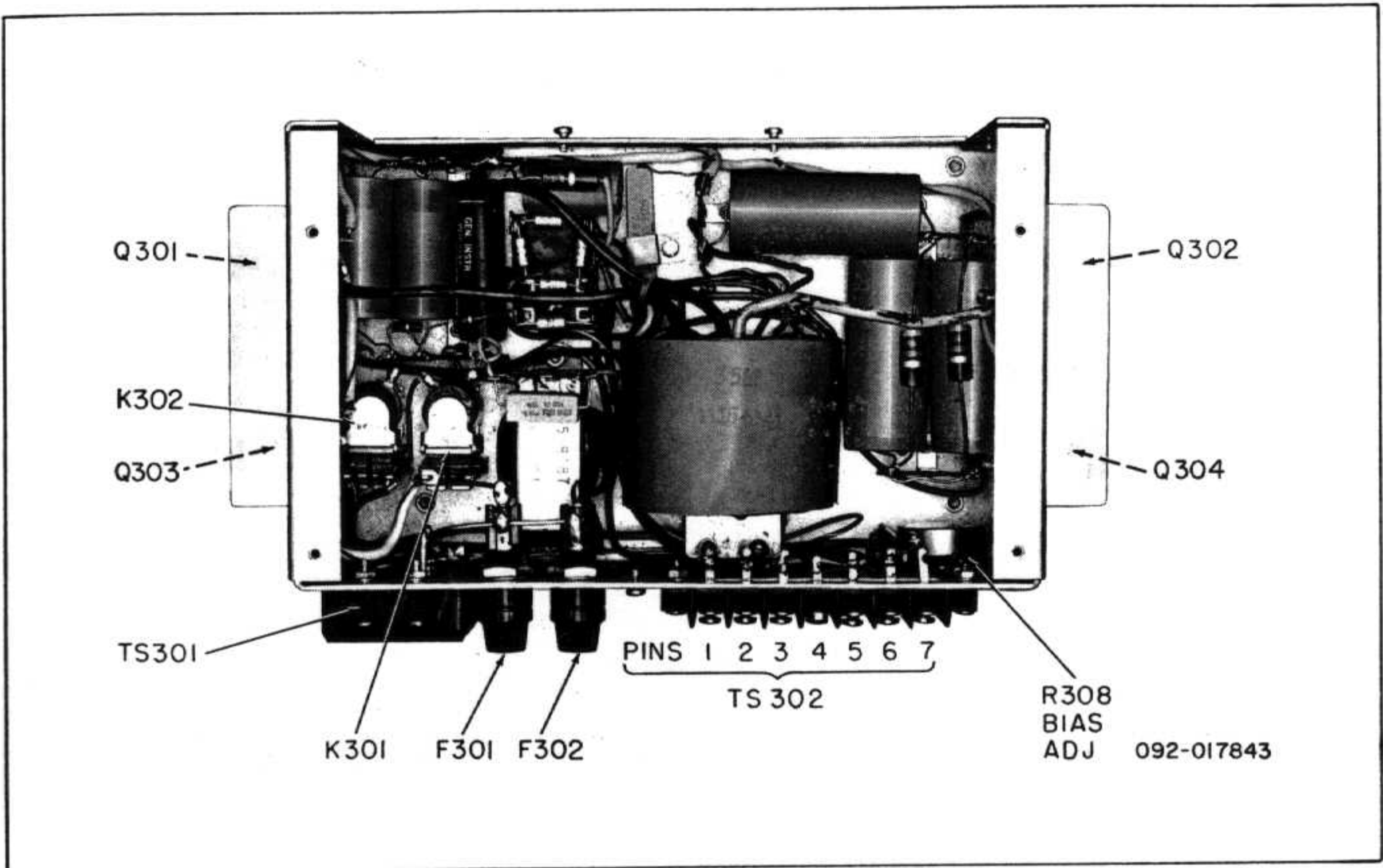

Figure 17. Internal Top View of Model PS-150-12 DC Power Supply.

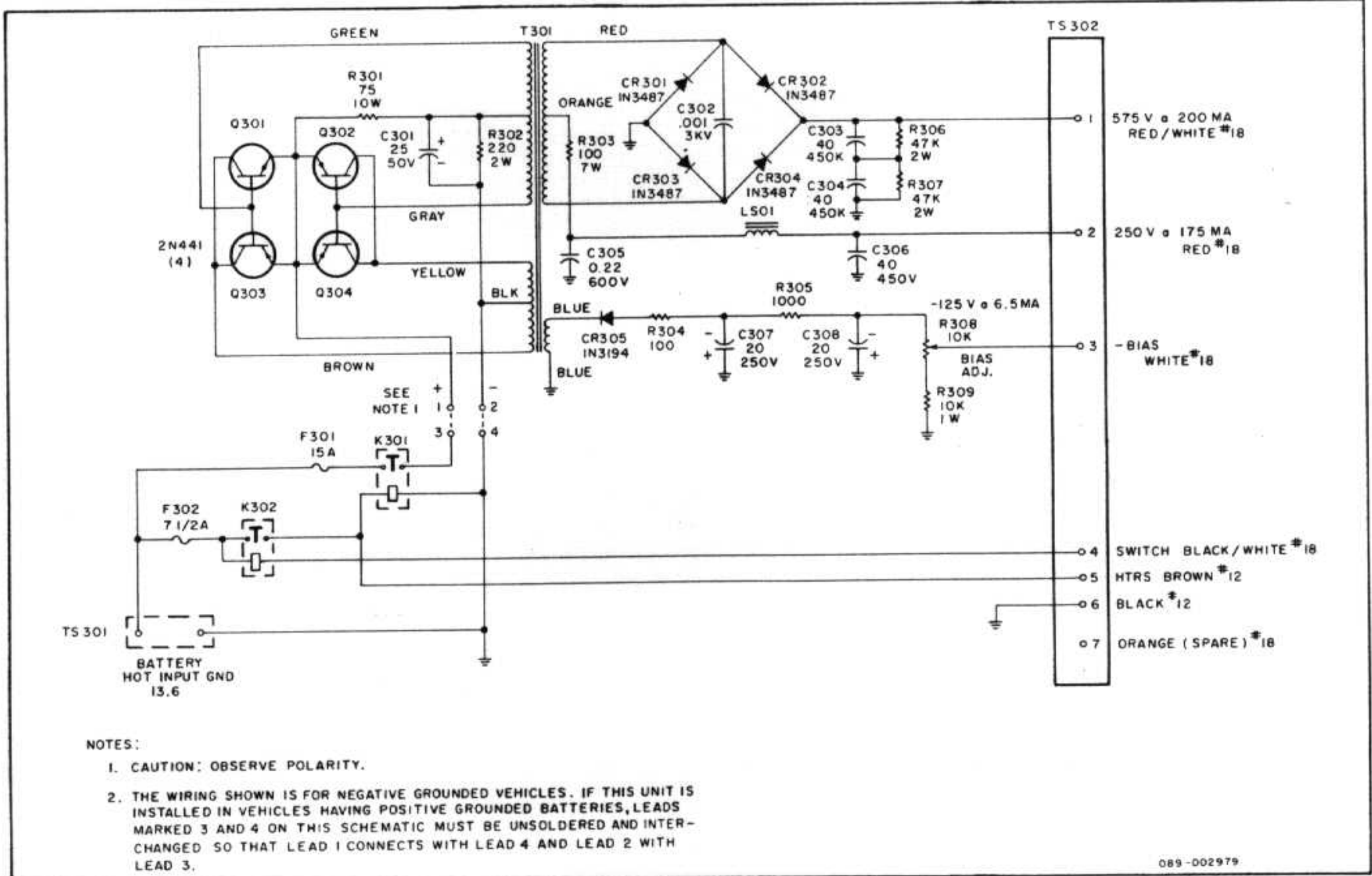

Figure 18. Schematic Diagram of Model PS-150-12 DC Power Supply.

SECTION XI

MOBILE MOUNTING RACK MODEL MR-150

11-1. DESCRIPTION.

Hallicrafters' Model MR-150 Mobile Mounting Rack is a sturdy, compact unit designed to facilitate mobile installation of the Model SR-150 Transceiver. This mounting rack, with mounting bracket and straps supplied, permits transmission hump, floor, and/or under dash mounting of the transceiver (see figures 4 and 5).

This rack is equipped with a cable for connection to the PS-150-12 Power Supply, an audio connector brought out to the side for connection to speaker, and provisions for a direct connection to a suitable antenna.

The side panels of the mounting rack fit snugly against the transceiver for a secure installation. Wing screws are supplied to attach the transceiver to these side panels.

Details for installing this equipment in a vehicle are described in paragraph 3-4 and in figures 4 and 5 of this handbook.

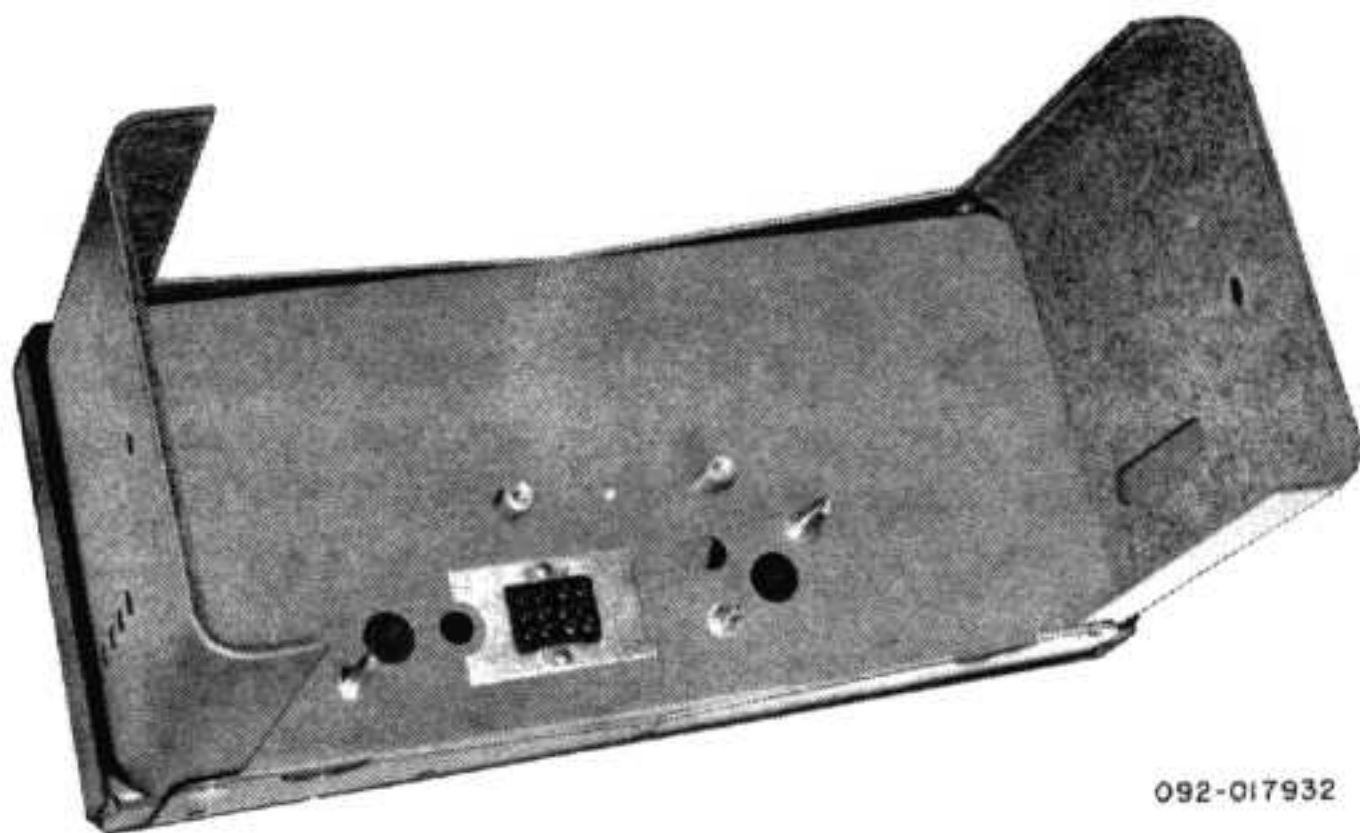

092-017932

Figure 19. Hallicrafters Model MR-150 Mobile Mounting Rack.

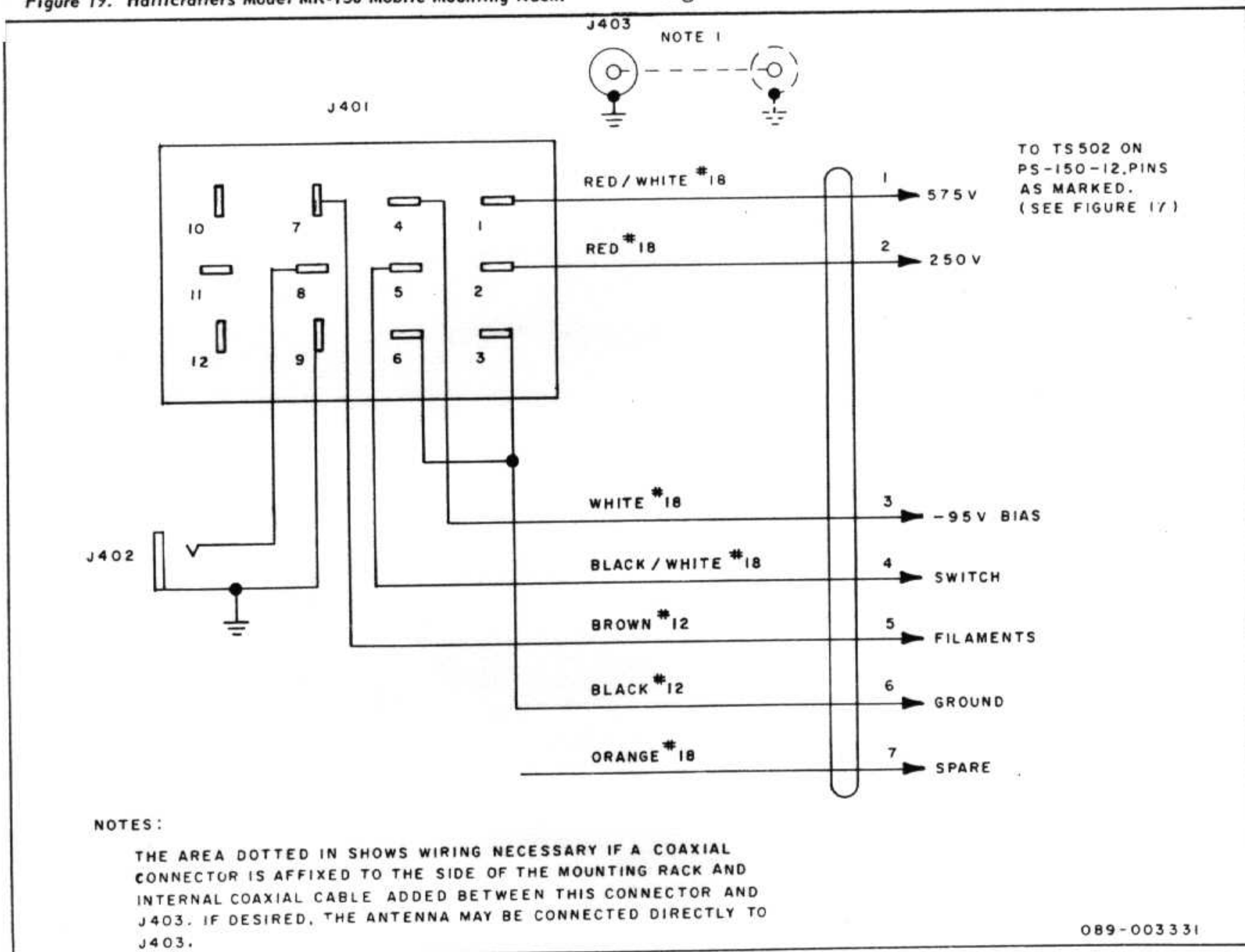

Figure 20. Schematic Diagram of Model MR-150 Mobile Mounting Rack.

REPAIR PARTS LIST FOR MR-150

Bracket, Mounting	067-010870
Cable Assembly	087-007656
Clamp, Cable	076-002744
Connector, Phone Type (Speaker)	036-000338
Connector, Power (12-pin)	010-002585
Connector, RF Type (Antenna)	035-000084
Guide Pin	074-002792
Knob, Decorative, Wing-Screw	015-001768
Pad, Side Bracket (Left)	014-000475
Pad, Side Bracket (Right)	014-000483
Strap, Mounting (2)	076-003202

SERVICE REPAIR PARTS

Schematic Symbol	Description	Hallcrafters Part Number	Schematic Symbol	Description	Hallcrafters Part Number
CAPACITORS			CAPACITORS (CONT)		
C1,18,145	18 μ F, 5%, 500V, Plastic Mica	482-132180	C104,105	330 μ F, 2%, 500V, Plastic Mica	482-161331
C2,19,147	85 μ F, 2%, 500V, Plastic Mica	482-161850	C114	10 μ F, 50V, Electrolytic	045-000755
C3,20,148	135 μ F, 2%, 500V, Plastic Mica	493-121350-334	C115 A&B	2 x 30 μ F, 350V, Electrolytic	045-000902
C4,24,25,143	15 μ F, 5%, 500V, Plastic Mica	482-132150	C119,123	0.001 μ F, 20%, 3000V, Ceramic Disc	047-100397
C5,70	22 μ F, 5%, 500V, Plastic Mica	482-152220	C121	5 μ F, \pm 0.5 μ F, 500V, Plastic Mica	493-110050-531
C6,23	3900 μ F, 2%, 500V, Plastic Mica	482-361392	C122	Variable, FINAL TUNING	048-000525
C7A,B,C, D,&E	Variable, PRESELECTOR	048-000526	C124	220 μ F, 2%, 500V, Plastic Mica	482-161221
C8,33,59,108	10 μ F, 5%, 500V, Plastic Mica	482-132100	C125	150 μ F, 2%, 500V, Plastic Mica	482-161151
C9,50,71	47 μ F, 2%, 500V, Plastic Mica	482-151470	C127,128, 129	390 μ F, 2%, 500V, Plastic Mica	482-161391
C10,12,13, 29,30,35,36, 37,41,68,69, 75,79,102, 116,132,133, 146,149,150, 151,162,166, 167	0.005 μ F, 20%, 500V, Ceramic Disc	047-100442	C131	0.01 μ F, +80%, -20%, 500V, Ceramic Disc	047-100224
C11,55,61, 112,117,137, 168,169,170, 171,179	0.02 μ F, 20%, 600V, Ceramic Disc	047-100471	C138	1000 μ F, 2%, 500V, Plastic Mica	482-261102
C15,164	Variable, Trimmer, 5 μ F to 25 μ F	044-100473	C140,141	510 μ F, 2%, 500V, Plastic Mica	482-261511
C16	125 μ F, 2%, 500V, Plastic Mica	493-121250-334	C142	270 μ F, 2%, 500V, Plastic Mica	482-161271
C17,22,26, 27,57,74,78, 81,126,130, 135,136,173, 174	100 μ F, 2%, 500V, Plastic Mica	482-161101	C144	680 μ F, 2%, 500V, Plastic Mica	482-261681
C21	33 μ F, 2%, 500V, Plastic Mica	482-151330	C163	27 μ F, 2%, 500V, Plastic Mica	482-151270
C28,31,34, 39,40,42,43, 44,46,51,53, 54,56,64,67, 82,84,107, 110,113,152, 154,159,160, 177	0.01 μ F, 20%, 500V, Ceramic Disc	047-100354	C175	0.002 μ F, 20%, 500V, Ceramic Disc	047-100395
C32A,B,C, D,&E	Variable, TUNING	048-000522	*RESISTORS		
C38	39 μ F, 2%, 500V, Plastic Mica	482-151390	R1,2,8,139, 143,146,149, 152,158	1 Megohm	451-252105
C45,47,49, 80,83,99,111, 134,153,155, 161,172,176	0.001 μ F, 20%, 500V, Ceramic Disc	047-001671	R3	160 Ohms	451-252181
C48	38 μ F, 2%, 500V, Plastic Mica	482-151360	R4 and 91, R46 and 140	Variable, Dual: 10K Ohms, 30%, 1 watt, RF GAIN and 500K Ohms, 30%, 1/4 watt, AF GAIN; 10K Ohms, 30%, 1 watt, RF LEVEL and 500K Ohms, 30%, 1/4 watt, MIC GAIN	025-002063
C52,72	82 μ F, 2%, 500V, Plastic Mica	482-161820	R5,11,17,24, 31,36,37,39, 40,49,52,64, 77,113,136, 137,159	47K Ohms	451-252473
C58,157, 165,178	0.22 μ F, 10%, 200V, Paper Tubular	046-001296-04	R6,81	180K Ohms	451-252184
C60,62,65, 109	470 μ F, 2%, 500V, Plastic Mica	482-261471	R7,27,30	15K Ohms	451-252153
C63,100	5 μ F, 25V, Electrolytic	045-000938	R9	150K Ohms	451-252154
C66,118, 120,158	0.1 μ F, +80%, -20%, 100V, Ceramic Disc	047-001428	R10,36,43, 141	2200 Ohms	451-252222
C73	120 μ F, 2%, 500V, Plastic Mica	482-161121	R12	100 Ohms	451-252101
C76	4.7 μ F, \pm 0.5 μ F, 500V, Plastic Mica	493-140470-531	R13,23	15K Ohms, 2 watts	451-652153
C77	8.8 μ F, \pm 0.5 μ F, 500V, Plastic Mica	493-140680-531	R14,15,18, 28,33,42,45, 50,53,54,55, 56,57,59,60, 63,69,73,114, 126,154	1000 Ohms	451-252102
C85,91,98, 101,156	1000 μ F, GMV, Ceramic Feed-Through	047-001308	R16,22,32	220 Ohms	451-252221
C86	3.3 μ F, \pm 0.5 μ F, 300V, Plastic Mica	493-140330-521	R19,29,51,66, 79,112,148	470K Ohms	451-252474
C87	Variable, Trimmer, 1 μ F to 12 μ F, 600V (Piston type)	044-000568	R20,34,67,74, 82,93,94,132	220K Ohms	451-252224
C88	27 μ F, 2%, 300V, Plastic Mica	481-151270	R21,65,124	22K Ohms	451-252223
C89	51 μ F, 2%, N30, Ceramic Tubular	491-024510-31	R25	82 Ohms	451-252620
C90	12 μ F, 5%, N470, Ceramic Tubular	491-005120-83	R26,35,41,75, 84,87,102,110, 115,125,135, 142,147,151, 157	100K Ohms	451-252104
C92	43 μ F, 2%, 300V, Plastic Mica	481-151430	R47,89,98,105	10K Ohms	451-252103
C93,94	910 μ F, 2%, 300V, Plastic Mica	481-261911	R48,100,108, 138	4700 Ohms	451-252472
C95	18 μ F, 5%, 300V, Plastic Mica	481-132160	R58	22K Ohms, 1/4 watt	451-152223
C96,139	Variable, Trimmer, 0.8 μ F to 13 μ F, 3000V (Piston type with hardware)	044-000520	R61	18K Ohms, 1/4 watt	451-152183
C97	68 μ F, 2%, 300V, Plastic Mica	481-161680	R62	27K Ohms, 1/4 watt	451-152273
C103,106	Variable, Trimmer, 8 μ F to 50 μ F	044-200437	R68	4700 Ohms, 2 watts	451-652472
			R70,83,101, 130	2700 Ohms	451-252272
			R71,129	68K Ohms	451-252683
			R72	680 Ohms	451-252681
			R76	2200 Ohms, 1/4 watt	451-152222
			R78	27K Ohms	451-252273
			R80	Variable, 25K Ohms, 30%, 1/3 watt, CAL ADJ	025-002061
			R82	Variable, 25K Ohms, 30%, 1/3 watt, RTT (Inc. 54)	025-002062
			R85,86,121	820 Ohms	451-252821
			R89,90	4.7 Megohms	451-252475
			R95	2500 Ohms, 10 watts, Wire Wound	453-062252
			R96,150	Variable, 1 Megohm; 30%, 0.2 watt, QT Gain and VOX Sensitivity	025-002067
			R97,156	8.2 Megohms	451-252625
			R99	47 Ohms, 1 watt	451-352470

LIST MODEL SR-150

Schematic Symbol	Description	Hallicrafters Part Number	Schematic Symbol	Description	Hallicrafters Part Number
* RESISTORS (CONT)			SWITCHES		
R103,133, 134,145	470 Ohms	451-252471	S1	Rotary, BAND SELECTOR (Inc. S1A)	060-002442
R104	2700 Ohms, 1 watt	451-352273	S1B,E	Wafer, Crystal Oscillator and Transmitter Mixer	062-000195
R107	470 Ohms, 1 watt	451-352471	S1C,D, F,H	Wafer, Antenna, RF Amplifier, Mixer, and Final Input	062-000198
R109	47K Ohms, 2 watts	451-852473	S1G	Wafer, Driver Output	062-000198
R111	270K Ohms	451-252274	S1J	Wafer, Final Pi-Output	062-000197
R116	1.5 Megohms	451-252155	S2	SPST, Antenna	060-100440
R117	2.2 Megohms	451-252225	S3	Rotary, CAL-OFF	060-002555
R118,122	3300 Ohms	451-252332	S4	SPST, RIT-OFF/ON	Part of R82
R119	82K Ohms, 1 watt	451-352823	S5	Rotary, FUNCTION	060-002441
R120	Variable, 50K Ohms, 20%, 0.2 watt, Meter Zero	025-002065	S8	Rotary, OPERATION (Inc. S7)	060-002443
R123	150 Ohms	451-252151	S7	SPST, POWER	Part of S8
R126	33K Ohms	451-252333	CRYSTALS		
R127	56K Ohms	451-252563	Y1	100 KC, Crystal Calibrate	019-002712
R131	Variable, 250 Ohms, 0.3 watt, Balance	025-002064	Y2 ***	36.0 MC, 10 Meters	019-002940-08
R144	3900 Ohms	451-252392	Y3 ***	35.5 MC, 10 Meters	019-002940-07
R153	330K Ohms	451-252334	Y4	35.0 MC, 10 Meters	019-002940-06
R155	Variable, 10 Megohms, 20%, 0.2 watt, Delay	025-002066	Y5 ***	34.5 MC, 10 Meters	019-002940-05
R160	1500 Ohms	451-252152	Y6	27.5 MC, 15 Meters	019-002940-04
* All RESISTORS are carbon type, 10%, 1/2 watt unless otherwise stated.			Y7	20.5 MC, 20 Meters	019-002940-03
COILS & TRANSFORMERS			Y8	13.5 MC, 40 Meters	019-002940-02
L1	Coil, Antenna, 15 Meters	051-003350	Y9	10.0 MC, 80 Meters	019-002940-01
L2	Coil, Antenna, 20 Meters	051-003347	Y10	1648.1 KC, LSB	019-002945-01
L3	Coil, Antenna, 40 Meters	051-003345	Y11	1651.7 KC, USB	019-002945-02
L4	Coil, Antenna, 80 Meters	051-003348	*** Not Supplied.		
L5	Coil, Antenna, 10 Meters	051-003531	CONNECTORS		
L8,13,16, 25,26,29, 33,36,42	Coil, 0.7 MH RF Choke	053-000530	J1,2,4	Antenna (Receiver and Common), 500-Ohm Output	036-100041
L7,37	Coil, Mixer and Driver, 10 Meters	051-003533	J3,5	PHONES and Key	036-200210
L8,38	Coil, Mixer and Driver, 15 Meters	051-003349	J6	Microphone (Inc. Hardware)	010-101589
L9,39	Coil, Mixer and Driver, 20 Meters	051-003342	J7	Power Input (12-pin Jones type)	010-002586
L10,40	Coil, Mixer and Driver, 40 Meters	051-003340	MISCELLANEOUS		
L11,41	Coil, Mixer and Driver, 80 Meters	051-003341	Cabinet		
L12	Coil, 6.0-MC to 6.5-MC Trap	053-000665	Cable Assembly (Harnessed)		
L14,15	Coil, IF, Filter Termination	050-000601	Coupler, Solid		
L17,18	Coil, Crystal Oscillator, 10 Meters	051-003353	Cover, Cabinet Bottom		
L19,20	Coil, Crystal Oscillator, 10 Meters	051-003343	Cover, Cabinet Top		
L21	Coil, Crystal Oscillator, 15 Meters	051-003529	Cover, VOX Relay		
L22	Coil, Crystal Oscillator, 20 Meters	051-003344	Dial Window		
L23	Coil, Crystal Oscillator, 40 Meters	051-003530	Disc, Dial (TUNING)		
L24	Coil, Crystal Oscillator, 80 Meters	051-003351	Emblem, Hallicrafters Logo		
L27	Coil, VFO	051-003509	Escutcheon		
L28	Coil, 27 μ H RF Choke	053-000666	Escutcheon Plate		
L30	Coil, 1 MH RF Choke	053-000580	FL1	Filter, Crystal Lattice	049-000216
L31	Coil, Final Amplifier RF Choke	053-200428	Foot, Plastic (4)		
L32	Coil, Final Amplifier Pi-Output	051-003348	Front Panel		
L34,35	Coil, Parasitic Choke Assembly	053-000678	Gear, Pinion		
T1,2	Transformer, Variable IF, 6.5 MC to 6.0 MC	050-000786	Gear, Spur (Fixed)		
T3	Transformer, IF, 1650 KC	050-000890	Gear, Spur		
T4,6	Transformer, BFO and Balanced Modulator Output	050-000881	Handle, Knob		
T5	Transformer, Output	055-000469	Iron Core (Coil Slugs)		
** ELECTRON TUBES & DIODES			Iron Core (L27 Only)		
V1	Tube, Type 6AZ8	090-901417	Knob, AF GAIN, MIC GAIN, and RIT (Round)		
V2,4	Tube, Type 12BA7	090-901474	Knob, BAND SELECTOR and FUNCTION		
V3,5,9,17	Tube, Type 6EA8	090-901350	Knob, CAL ADJ and CAL-OFF		
V6	Tube, Type 12BE6	090-900040	Knob, FINAL TUNING and PRESELECTOR		
V7	Tube, Type 6AH6	090-900793	Knob, OPERATION		
V8,10,19	Tube, Type 12AT7	090-900034	Knob, RF GAIN, RF LEVEL, and RIT OFF/ON (Bar)		
V11	Tube, Type 6T8A	090-901403	M1	Meter	082-000566
V12	Tube, Type 0A2	090-900001	DS1	Pilot Lamp, NO. 1815	039-000689
V13	Tube, Type 6AQ5A	090-901331	Pointer, FINAL TUNING and PRESELECTOR		
V14,15	Tube, Type 12DQ6B/12GW8	090-901475	Pointer, TUNING Dial		
V16	Tube, Type 12BY7A	090-901192	K2,3	Relay, RF Switching and Antenna	021-000651
V18	Tube, Type 12AX7/ECC83	090-901230	K1	Relay, VOX	021-200442
CR1,2,3,5, 6,7,8,9	Diode, Type 1N295	019-301980	Screw, Machine (TUNING knob spinner)		
CR4	Diode, Type V-100, Varicap	048-000464	Skirt, TUNING Knob		
CR10,11	Diode, Type 1N87	019-002941	Spring, Anti-Backlash		
			Switch Wafer (Dummy)		
			Washer, TUNING Knob Spinner		

** See Section II, Page 3 for Tube Functions.

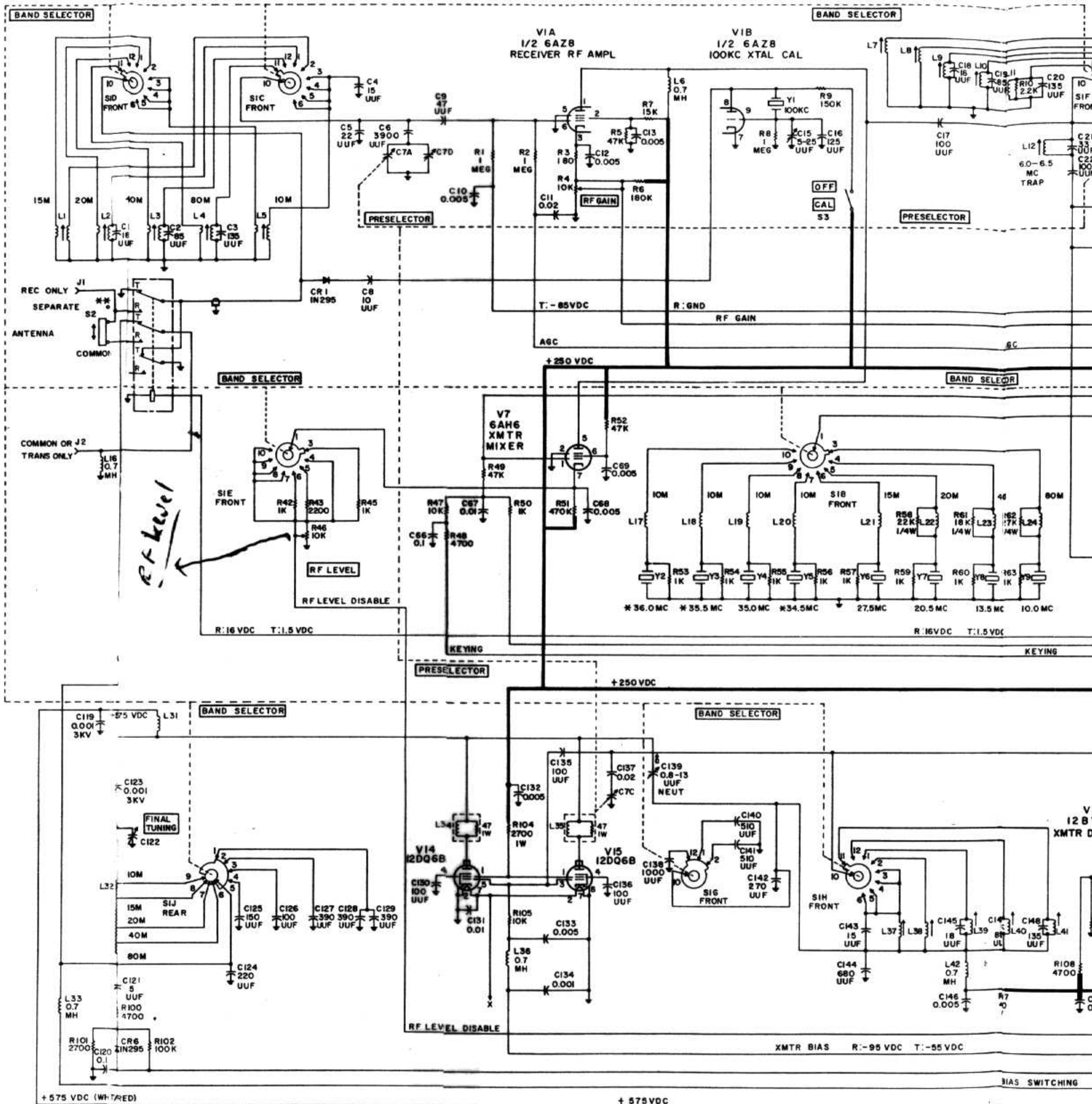

NOTES:
 UNLESS OTHERWISE SPECIFIED;
 ALL RESISTORS ARE IN OHMS ± 10%, 1/2 WATT.
 ALL CAPACITORS ARE IN UF (SEE PARTS LIST FOR VOLTAGE RATING)
 1. OPERATION SWITCH IS SHOWN IN OFF (FULL CCW) POSITION
 FUNCTION SWITCH IS SHOWN IN CW (FULL CCW) POSITION.
 2. BAND SWITCH IS SHOWN IN 3.5 MC (FULL CCW) POSITION.
 * CRYSTALS NOT SUPPLIED.
 ** SEPARATE ANTENNAS OR LINEAR AMPLIFIER WITH
 ANTENNA SWITCHING RELAY USE THIS POSITION.
 3. ALL FEEDTHRU CAPACITORS ARE 1000 UUF.

FUNCTION SW POSITION	OPERATH SW POSITION
1. OFF (POWER OFF)	1. CW
2. STANDBY (RECEIVE)	2. USB
3. MOX (MANUAL XMIT/PTT)	3. LSB
4. VOX (AUTOMATIC XMIT)	
SHOWN IN OFF	SHOWN IN CW

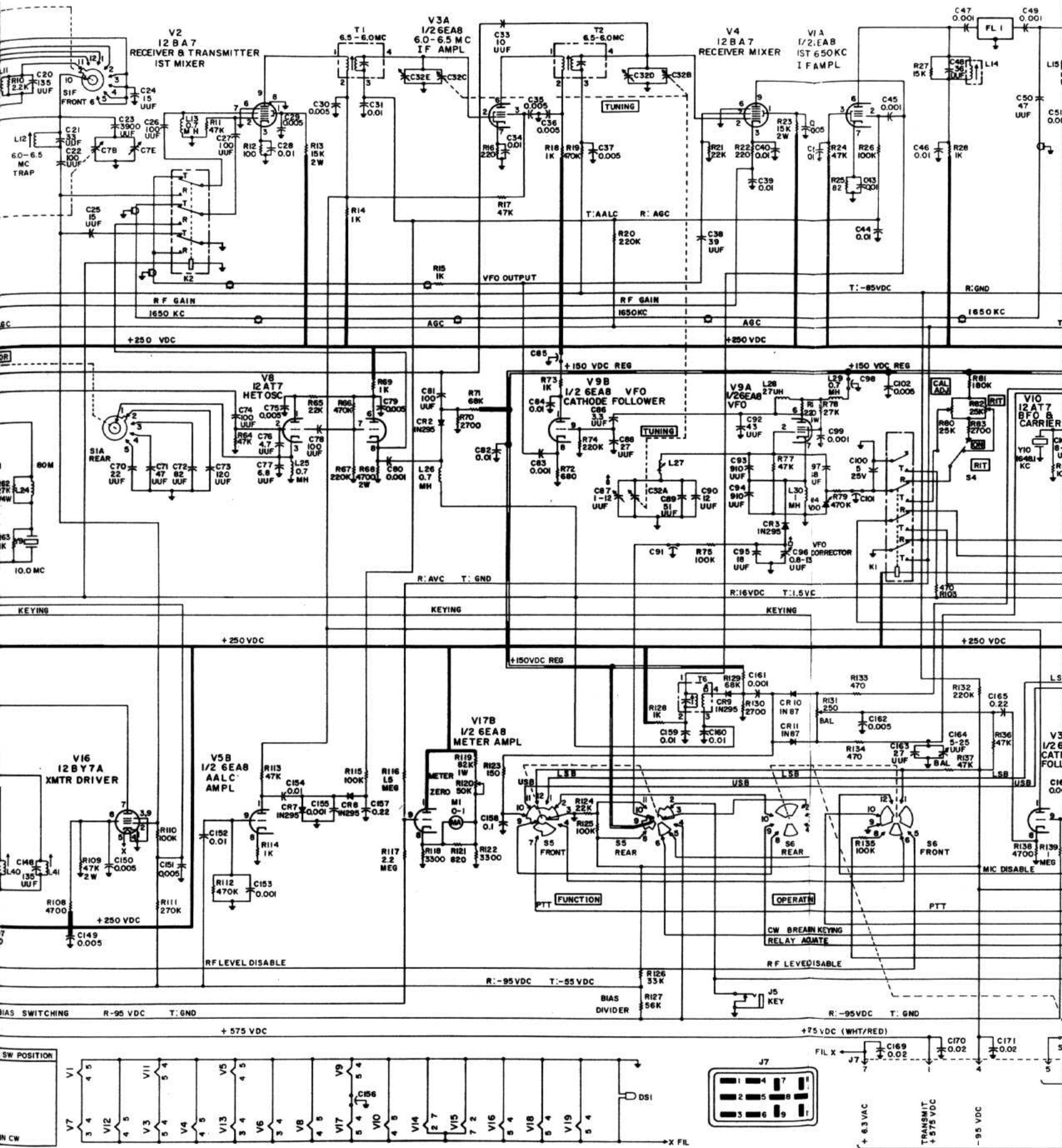

Figure 21. Schematic Diagram of Model SR-150 Transceiver.

